

TUBE•LINE™

Tubeline Manufacturing Limited
6455 Reid Woods Drive RR #4
Elmira, Ontario, Canada N3B 2Z3

Email: sales@tubeline.ca

Fax: 519.669.5808

Tel: 519.669.9488

Toll-free (North America): 1.888.856.6613

www.tubeline.ca

Operator's Manual

Keep this manual with the machine at all times.



Bale Processor

Boss II HD

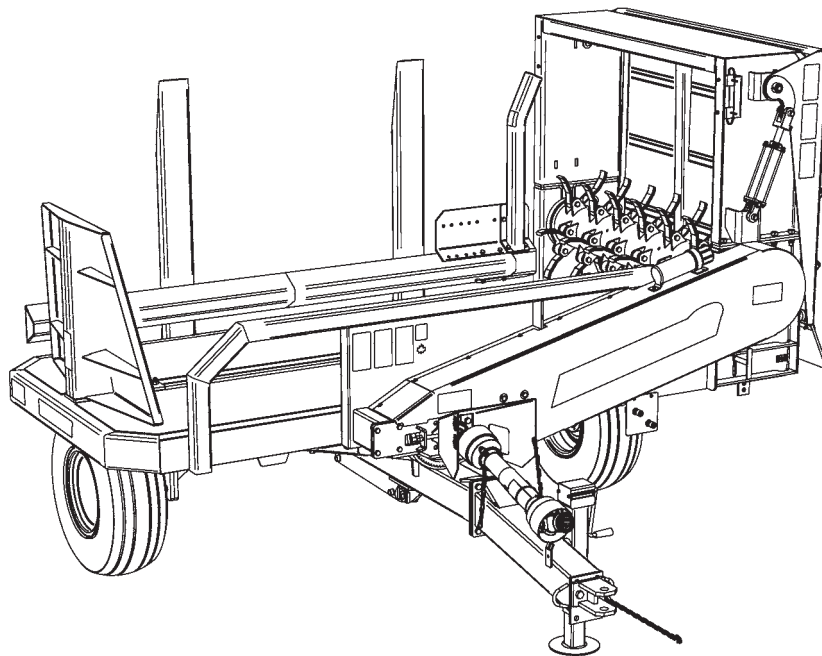

Do not attempt to operate this machine without thoroughly reviewing this manual for safe and proper operation.

Operator's Manual

Thank you for choosing the Tubeline Boss II HD Series Bale Processor. We know it will give you many years of productive service. Please read and understand this manual and the machine before operation.

Warranty and Limitation of Liability

All equipment is sold subject to mutual agreement that it is warranted by the company to be free from defects of materials and workmanship. But the company shall not be liable for special, indirect or consequential, damages of any kind under this contract or otherwise. The company's liability shall be limited exclusively to replacing or repairing without charge, at its factory or elsewhere, at its discretion.

Any material, or workmanship defects which become apparent within one year from the date on which the equipment was purchased, and the company shall have no liability for damages of any kind. The buyer by the acceptance of the equipment will assume all liability for any damages, which may result from the use or misuse by his employees or others.

Warranty coverage is null and void unless Warranty Registration form has been completely filled in and is on file at Tubeline Manufacturing Ltd.

Manuals

Manuals are printed and shipped with machines as they leave the manufacturer. Your machine may include parts or features not yet included in the initially shipped manual. The latest manual version can be found at www.tubeline.ca/support.php. Tubeline reserves the right to update and change manuals as seen fit. Dealers are informed of any pressing changes/ modifications. They can help you with any questions regarding replacement parts.

Serial Number

The serial number plate is located on the right side of the front hitch tube of your Tubeline Boss II HD machine. This number helps us to track changes and improvements and must be mentioned when ordering parts or requesting service. For your convenience, a space has been provided inside the front cover of this manual to record the serial number, model number, purchase date, and dealer name.

Model No: Boss II HD

Serial No: _____

Date Purchased : _____

Dealer Name : _____

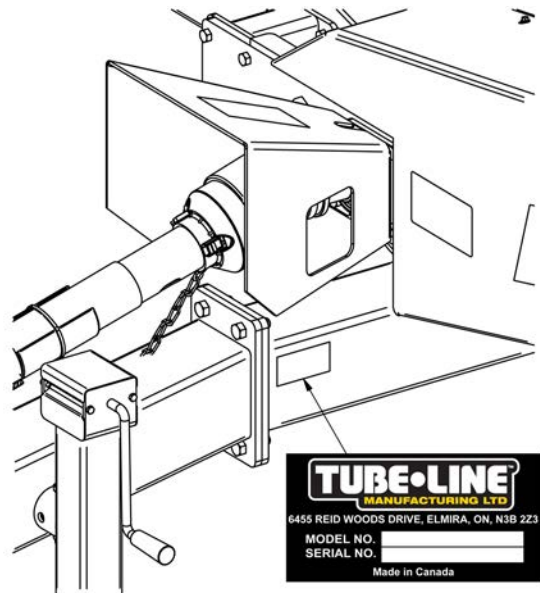

Table of Contents

Operator's Manual	I
Warranty and Limitation of Liability	I
Manuals	I
Serial Number	I
Section 1 - Introduction	1-1
Orientation & Terminology	1-1
Bale Sizes	1-1
Intended Use	1-1
Power Unit Specifications	1-2
Wheel Load Index Charts	1-2
Section 2 - Safety	2-1
Safety Symbol	2-1
Safety Words	2-1
General Safety	2-1
Personal Protective Equipment	2-1
Operation Safety	2-2
Hydraulic Safety	2-2
PTO Safety	2-2
Tire Safety	2-3
Maintenance Safety	2-3
Safety Decal Instructions	2-3
Safety Decals - New Style	2-4
Safety Decals - Old Style	2-7
Section 3 - Processor Operation	3-1
Adjustments	3-1
Processor Hookup	3-2
Starting Machine	3-2
Using On Inclines	3-2
Loading Bales	3-3
Spreading Bales	3-3
Transportation	3-3
Section 4 - Processor Maintenance	4-1
Before First Use	4-1
Before Each Use	4-1
After Every 10 Hours of Operation	4-1
Repairs	4-1
PTO Driveline	4-2
Storage	4-2
Grease Points	4-2
Grease Point Locations	4-3

Section 5 - Part Breakdowns & Lists	5-1
Hitch Frame	5-2
Flail Drum - Current	5-4
Flail Drum - Old Style(s)	5-4
Belt Drive	5-6
Fork	5-8
Ram	5-10
Deflector Shield	5-12
Hydraulic Layout - Original	5-14
Hydraulic Layout - Original (Rev.1-0 Update)	5-16
Hydraulic Layout - Current	5-18
BS208140 - 1000RPM PTO (Standard)	5-20
BS208540 - 540RPM PTO (Option)	5-22
Wiring Harness - Diverter Valve Machines	5-24
Section 5 - Options	5-25
BossCK - Adjustable Knife Kit	5-25
Imperial Torque Value Chart.	V
Metric Torque Value Chart	VI

Intentionally Left Blank

Section 1 - Introduction

The Boss II HD is carefully designed and manufactured to give you many years of dependable service. You or any other person, who will be assembling, operating, maintaining or working with this product, are required to read and completely understand the information and instructions contained in this manual. If anyone does not fully understand every part of this manual, please obtain further assistance by contacting the dealer from which this product was purchased or by contacting Tube·Line at the telephone number or address listed on the previous page of this manual. Keep this manual available for reference whenever this product is being handled or used. Provide this manual to any new owners and/or operators.

Orientation & Terminology

Facing forward on power unit determines right and left sides of the machine. Directions are determined in relation to the operator of the equipment when seated in the normal operating position.

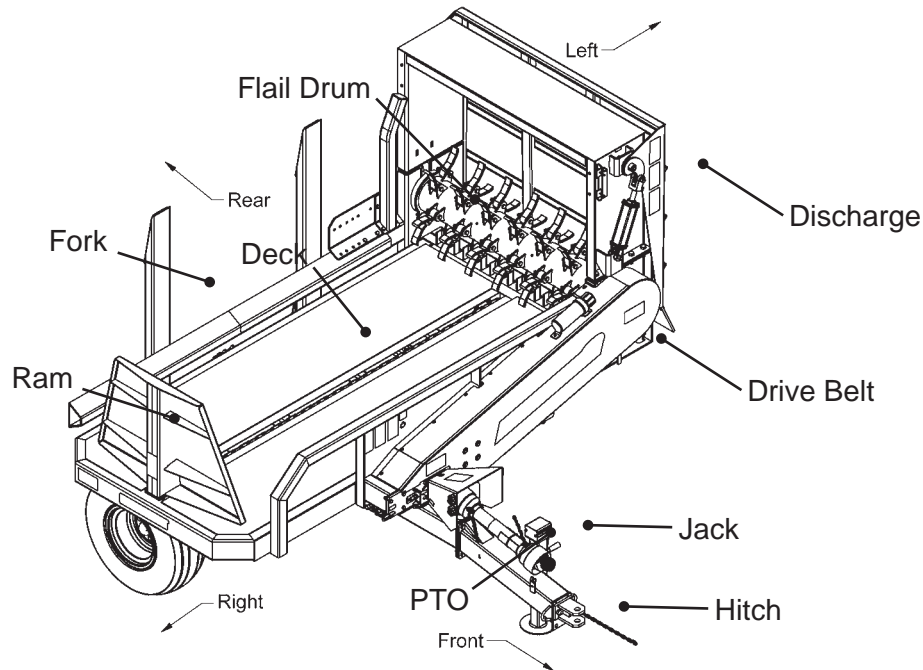

Bale Sizes

The Tubeline Boss II HD was designed to load and shred all types of forage in large square bales.

Maximum bale weight is 2800lbs (1270 kg).

Maximum length of bales is 108" (274 cm) X 58" (147 cm) X 58" (147 cm).

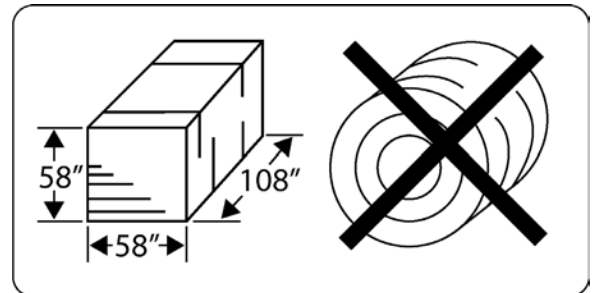

Intended Use

The Tubeline Boss II HD has many uses, including:

- Laying windrows in open fields.
- Filling feed bunks - fence line, circular, etc.
- Spreading forage for livestock bedding.
- Spreading mulch over perennial plants such as strawberries and mushrooms.
- Retractable knife section for commodity chopping.

Power Unit Specifications

NOTE: Exceeding any of the recommended power unit specifications CAN result in damage to your power unit and/or this product and **WILL** void all Tubeline warranties.

MINIMUM	MAXIMUM
20 GPM at 2500 PSI	40 GPM at 3000 PSI

Power unit horse power required: 60 HP minimum. Use caution when using power unit with more than 180 HP.

Tire size: 12.5L-15 Tire

Length: 132" (335 cm)

Width: 140" (356")

Height: 93" (236")

PTO: 1000 RPM (540 optional)

Wheel Load Index Charts

Replacement tires must match or exceed the specifications in that size tire's chart.

12.5L-15 I-1

Tire Size	Type	Rim	Unloaded		Static Load Radius	Rolling Circumference	Ply Rating	Load Index	Pressure	Load Capacity (lbs)
			OD	SW						Free Rolling 31 mph
12.5L-15	TL	10"	32.4"	12.6"	14.2"	95.5"	12	FR 127B	52psi	3420

31X15.5-15 (Optional Lug Tire)

Tire Size	Type	Rim	Unloaded		Static Load Radius	Rolling Circumference	Ply Rating	Load Index	Pressure	Load Capacity (lbs)
			OD	SW						30 mph
31X15.5-15	TL	13 LB	31.5"	15.4"	13.9"	91.3"	8	FR 116B	45psi	2760
								DR 116B	45psi	2760

Section 2 - Safety

Safety Symbol



This safety alert symbol is found throughout this manual to call your attention to instructions involving yourself and others working around the machine. Failure to follow these instructions can result in injury or death. This symbol means: **Attention! Become Alert! Your Safety is involved!**

Safety Words

CAUTION: Indicates a potentially hazardous situation that may result in injury.

WARNING: Indicates a potentially hazardous situation that could result in serious injury or death.

DANGER: Indicates a hazardous situation that needs to be avoided. It is you the operator that needs to be aware of these dangers.

NOTE: Informative only, not hazard or safety related.

General Safety

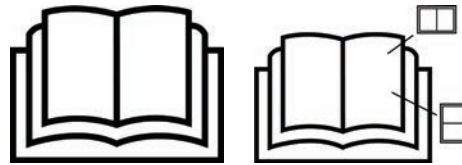

Take the necessary precautions to avoid injury or death. These include:

- Reading and understanding this manual before operating.
- Have training and train new operators.
- Review the safety instructions with all users annually.
- Know where safety decals are and what they convey.
- **DO NOT** paint over, remove or deface any safety signs or warning decals on your equipment.
- Replace damaged and/or missing safety decals.
- **DO NOT** operate without fully installed shields.
- Reinstall any removed shields **BEFORE** operating.
- Inspect machine before operating.
- **DO NOT** operate this machine while under the influence of drugs or alcohol.
- **DO NOT** let children ride or operate this machine.

Personal Protective Equipment



WARNING: Wear work boots, gloves, and safety glasses when maintaining or repairing machine.

WARNING: Wear work boots and ear protection when operating machine.

DANGER: Secure loose clothing, hair, accessories, etc before operating or maintaining the Boss II HD.

Boss II HD - Section 2 - Safety

Operation Safety



WARNING: Only use a tractor with a ROPS cab and seat belt. Secure your seat belt before operating machine.

DANGER: Never allow riders on bale processor. There is no safe place for any riders even for troubleshooting issues. Keep others away from your work area.

Read and completely understand the manuals and decals provided with your power unit.

Know all your power unit controls and know how to quickly stop all power unit movements, the processor movement, and the engine in case of emergency.

Know and obey all applicable government rules, O.S.H.A regulations, local laws and other professional guidelines for your operation.

When your power unit is used during any type of assembly, operation, maintenance or other work on or near this product:

Before leaving the operator's station apply your power unit's parking brake, stop the engine, remove the starter key, wait for all moving parts to stop and then relieve all pressure in the hydraulic lines.

Never allow anyone, except the operator, to be around the power unit or this product when either is in motion.

Do not start up unless others are clear of the work area.

Do not allow riders on this product or the power unit.

Hydraulic Safety



WARNING: Obey all safety instructions listed in this section and throughout this manual. Failure to obey instructions in this section could result in death or serious injury.

When dealing with hydraulics during any type of assembly, operation, maintenance or other work on or near this product:

Hydraulic fluid under pressure can penetrate the skin and cause serious injury or death. Hydraulic leaks under pressure may not be visible. Wear safety glasses, protective clothing and use a sound piece of cardboard or wood when searching for hydraulic leaks. **DO NOT USE YOUR HANDS!** If any fluid penetrates the skin, **SEEK IMMEDIATE MEDICAL ATTENTION!**

Before connecting or disconnecting hydraulic hoses, read your power unit's operator's manual for detailed instructions on connecting and disconnecting hydraulic attachments. Make certain that all parts meet the specifications for this product when installing or replacing hydraulic hoses or fittings. After connecting hydraulic lines: Slowly and carefully raise the loader and cycle the rollback / dump cylinders to check hose clearances and to check for any interference. Operate the hydraulics on this product to check hose clearances and to check for any interference. Make certain that the hoses cannot interfere with or actuate the quick-attach mechanism. Make certain that hoses will not be pinched, or get tangled, in any equipment. Do not lock the auxiliary hydraulics of your power unit in the **"ON"** position.

PTO Safety

Under no circumstances should a processor equipped for 540 rpm PTO be operated with 1000 rpm PTO. Nor should a 1000 rpm PTO processor be operated by a tractor with 540 rpm PTO.

Tire Safety



DANGER: Failure to follow proper mounting procedures when mounting a tire on a wheel or rim can produce an explosion which may result in serious injury or death.

- Do not attempt to mount a tire unless you have the proper equipment and experience to do the job.
- Have a qualified tire dealer or repair service perform required tire maintenance.
- When replacing worn tires, make sure they meet the original tire specifications.

NOTE: Proper tire pressure and maximum load details can be found on [pg. 1-2](#).

Maintenance Safety

Make sure that anyone who will be assembling, mounting, maintaining, repairing, removing and/or storing this product:

- Has been instructed in the safe operation of this product and of the power unit to which this product is attached.
- Is physically and mentally capable of the safe operation of this type of equipment.
- Is not under the influence of drugs or alcohol.
- Is carefully supervised from a safe distance, especially if such person is inexperienced.
- Has annually reviewed all safety instructions.
- Work on a level surface in a well lit area.
- Keep the area clean and dry.
- Use properly grounded electrical outlets and tools.
- Use the right tool for the job at hand.
- Make sure that your tools are in good condition for performing the desired function.

Do not place any part of your body under any part of this product unless this product is securely resting on adequate blocking or on the ground.

Safety Decal Instructions

Clean the area of application with non-flammable solvent, then, wash the same area with soap and water. Allow the surface to fully dry. Remove the backing from the safety sign, exposing the adhesive surface. Apply the safety sign to the position shown in the diagram above and smooth out any bubbles.

- Keep all safety decals clean and legible.
- Replace all missing, illegible or damaged safety decals.
- Replacement parts for parts with safety decals attached must also have safety decals attached.
- Safety decals are available free of charge from your dealer or from Tube-Line.

Safety Decals - New Style

NOTE: Decal illustrations may no be to scale.

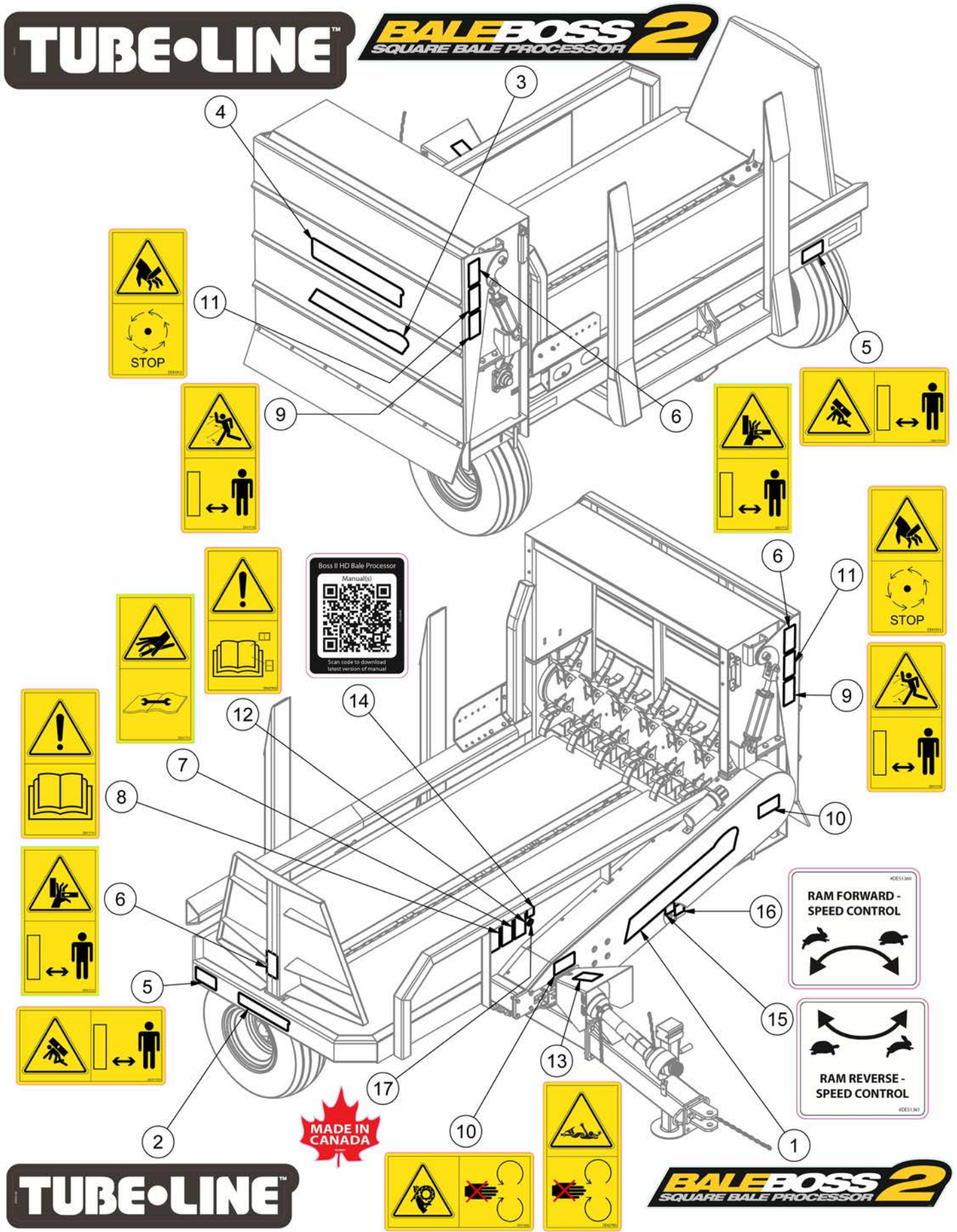

ITEM	QTY	PART NUMBER	DESCRIPTION
1	1	DE27275	BossII Processor Decal - 6 x 39.0
2	1	DE28146	Tubeline Decal 4" x 16"
3	1	DE28722	Bale Processor BossII - 4 x 32 Decal
4	1	DE30837	Tubeline Decal 7.25" x 30"
5	2	DE41711H	ISO Decal - Angled Crush Horizontal
6	3	DE41712	ISO Decal - Hand Pinch Point
7	1	DE41713	ISO Decal - High Pressure Fluid
8	1	DE41714	ISO Decal - Read Operator's Manual
9	2	DE41718	ISO Decal - Thrown Object Vertical
10	2	DE41902	ISO Decal - Chain Entanglement
11	2	DE41913	ISO Decal - Cutting Hazard
12	1	DE42784	ISO Decal - Read OM Decals Section
13	1	DE42785	ISO Decal - PTO Entanglement
14	1	DE50046	Boss II HD QR Decal
15	1	DE51360	Forward Speed Control Decal
16	1	DE51361	Reverse Speed Control Decal
17	1	DECANADA	Decal Made In Canada

Item: 1 & 3

Part No: DE27275 & DE28722



Item: 2 & 4

Part No: DE28146 & DE30837



Item: 14 Part No: DE50046

Scan code with smartphone to access manual online.



Item: 15 Part No: DE51360

Increase ram forward speed by turning knob counter-clockwise or clockwise to decrease.

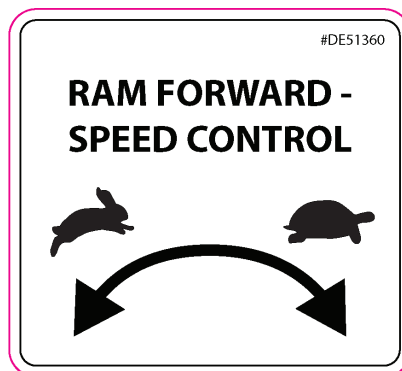

Item: 16 Part No: DE51361

Increase ram reverse speed by turning knob counter-clockwise or clockwise to decrease.

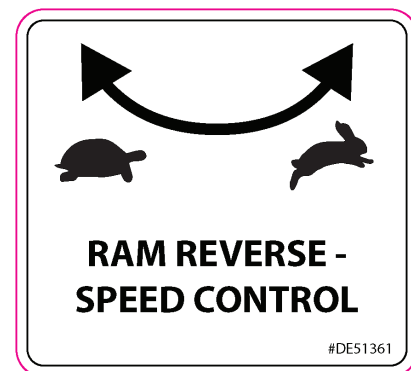

Item: 5 Part No: DE41711H

Stand clear of loading fork to avoid crushing hazard.



Item: 6 Part No: DE41712

Stand clear of lowering endgate to avoid pinching hazard.



Item: 7 Part No: DE41713

High pressure fluid hazard. Refer to maintenance section for proper leakage testing.

Item: 9 Part No: DE41714

Read and understand manual before operating this machine.



Item: 10 Part No: DE41718

Stand clear of feed path to avoid thrown material.



Item: 11 Part No: DE41902

Do not remove shields before drive components have completely stopped. Keep hands away while machine is in operation.

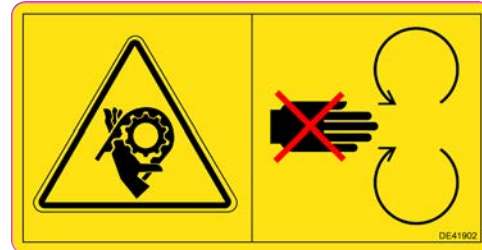

Item: 12 Part No: DE41913

Wait until all machine components have stopped moving before touching.



Item: 13 Part No: DE42784

Read and understand decal section of manual before operating this machine.



Item: 14 Part No: DE42785

Stand clear of rotating PTO driveline to avoid serious injury or death.



**Item: 15
Part No: DECANADA**



Safety Decals - Old Style

NOTE: Decal illustrations may not be to scale.

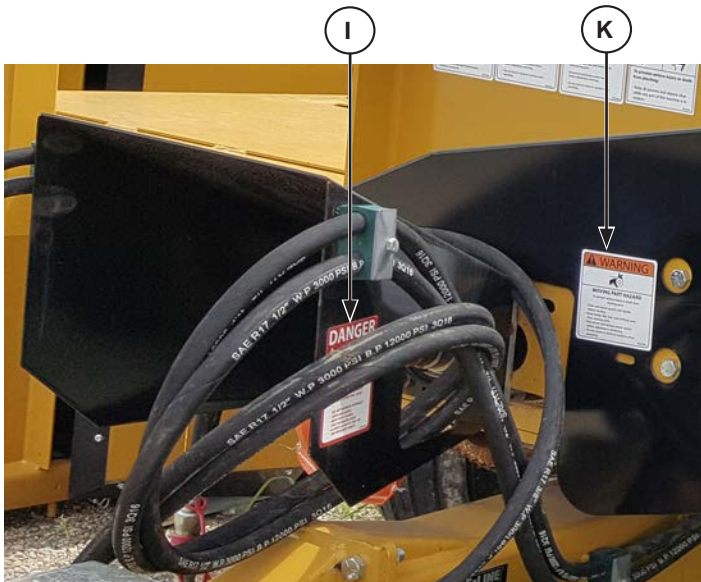
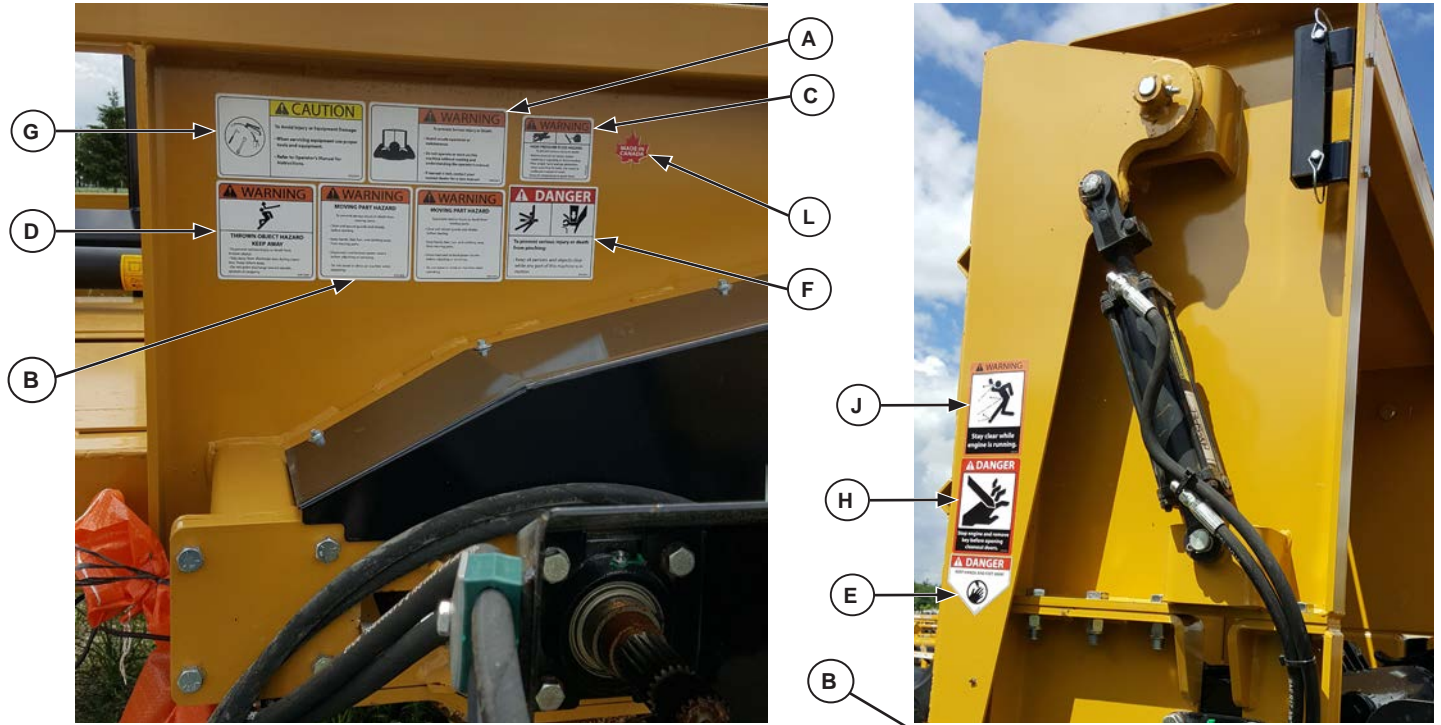

Item: A
Part No: DE23839

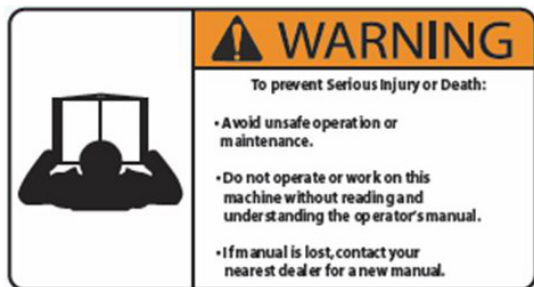

Item: B
Part No: DE23845



Item: C
Part No: DE23847



Item: D

Part No: DE23848



Item: E

Part No: DE23837



Item: F

Part No: DE23851



Item: G

Part No: DE23840



Item: H

Part No: DE23850



Item: I

Part No: DE23849



Item: J

Part No: DE23984



Item: K

Part No: DECANADA



Item: L

Part No: DE23845



Section 3 - Processor Operation

Adjustments

Drive belt can stretch over time which may cause slipping. Belt can be tightened by moving the PTO drive assembly.

- Loosen 4 bolts on PTO drive assembly. **DO NOT REMOVE!**
- Loosen nuts from threaded rod of PTO drive assembly.
- Move PTO drive assembly towards right side of machine.
- Tighten nuts against frame to set PTO drive assembly's new position.
- Tighten nuts and bolts on PTO drive assembly to finish setting new position.

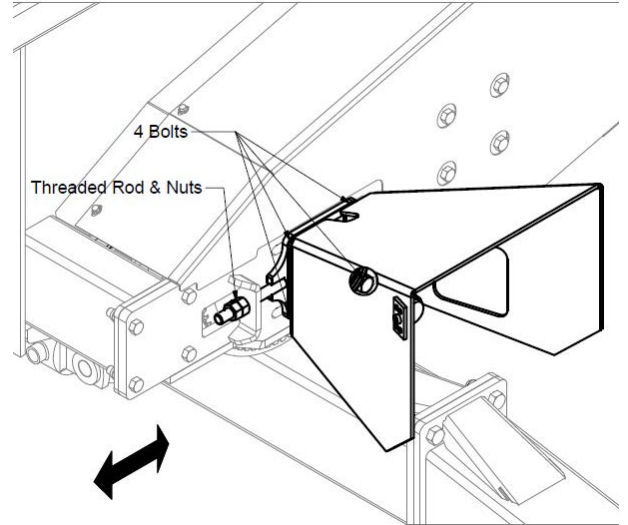

Replacement parts, for parts with safety decals attached, must also have safety sign attached.

The bale knife kit can be adjusted up or down. This can be useful if material is thick and is accumulating in the discharge/flail drum area.

To adjust, simply untighten the handle on each end, lower/raise to desired height, and retighten.

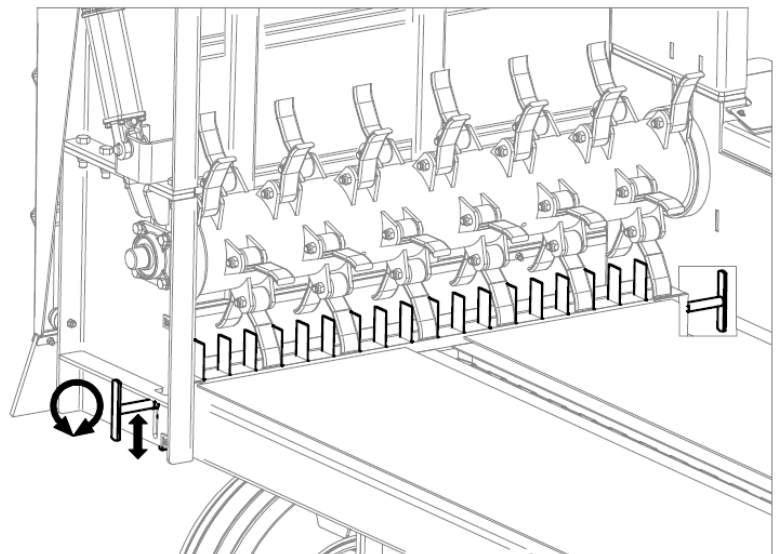

SAFETY FIRST

Read and understand the safety instructions on [pg.2-2](#) **BEFORE** beginning any processor operation.

DANGER

Failure to obey the following procedure will result in death or serious injury. Avoid contacting overhead wires.

WARNING

Failure to obey the following procedures could result in death or serious injury. Never lift this product: above the operator's eye level OR to a height where visibility is obstructed, whichever is lower. Use caution when raising loaded processor. Objects could fall from processor toward bystanders or operator. Remove all foreign objects from bales.

Processor Hookup

Refer to the power unit operator's manuals for special or detailed mounting instructions.

Inspect driveline shield for free rotation. Replace all damaged or excessively worn parts and hardware only with genuine Tube-Line parts or with properly rated fasteners, hydraulic hoses or fittings. Make certain that all locking pins, latches and connection devices are properly installed and secured. Make certain that all shields are in place and secure. Remove all foreign objects from processor.

NOTE: Refer to your power unit's operator's manual for safe operating limit and use of counterweights.

1. Reverse power unit until drawbar is positioned to allow a pin to connect the drawbar and processor hitch. Raise or lower the processor jack if necessary.
2. Fasten the processor safety chain to the power unit frame. Allow some slack for turning.
3. Connect the processor's PTO to the tractor's PTO stub shaft. Proper and adequate length of the drive-line must be maintained in order to have maximum one third engagement of telescoping tubing.
Too short of a drive-line will result in premature failing of the drive-line.
Too long of a drive-line will result in damage to drive-line, tractor PTO and implement.

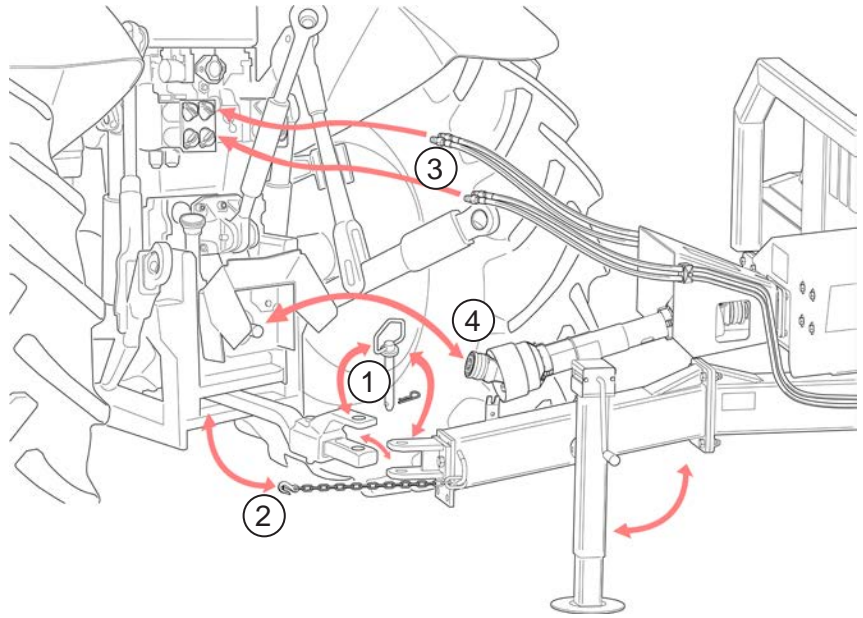

WARNING: Tractor PTO must be disengaged and tractor shut off before approaching or contacting the PTO shaft drive-line.

WARNING: Read and understand [Section 2: Safety](#) before beginning any hydraulic connection.

4. Disconnect the 6 hydraulic hose quick couplers from one another and attach to your power unit as per the instructions in your power unit's operator's manual. When attaching Boss II HD quick couplers to power unit, take note which lines are connected to which hydraulic control. The 1/2" hoses control the ram, the 3/8" hoses control the bale fork and discharge flap.

Starting Machine

Make sure that bales are free from foreign objects. Foreign objects in bale may cause damage to the machine or cause injury or death to livestock, bystanders, or operator.

DANGER: Make sure any bystanders are safely away from the machine and discharge before engaging PTO. Flying objects can cause serious injury or even death.

Engage the power unit PTO control to drive the processor belt, which turns flail drum. Engage the tractor hydraulics to power the ram forward and reverse, lift and lower the fork, and open or close the discharge flap.

Using On Inclines

When working on inclines or slopes, travel uphill or downhill, not along inclines. Be sure to keep tractor transmission in gear when traveling downhill.

Loading Bales

Load one bale at a time. If bales are frozen, put frozen side down to the table for better operation.

1. Lower the fork until it lightly engages with ground.
2. Reverse Boss II HD towards bale on ground.
3. When bale is centered on the fork, engage fork hydraulics to load on to the table.

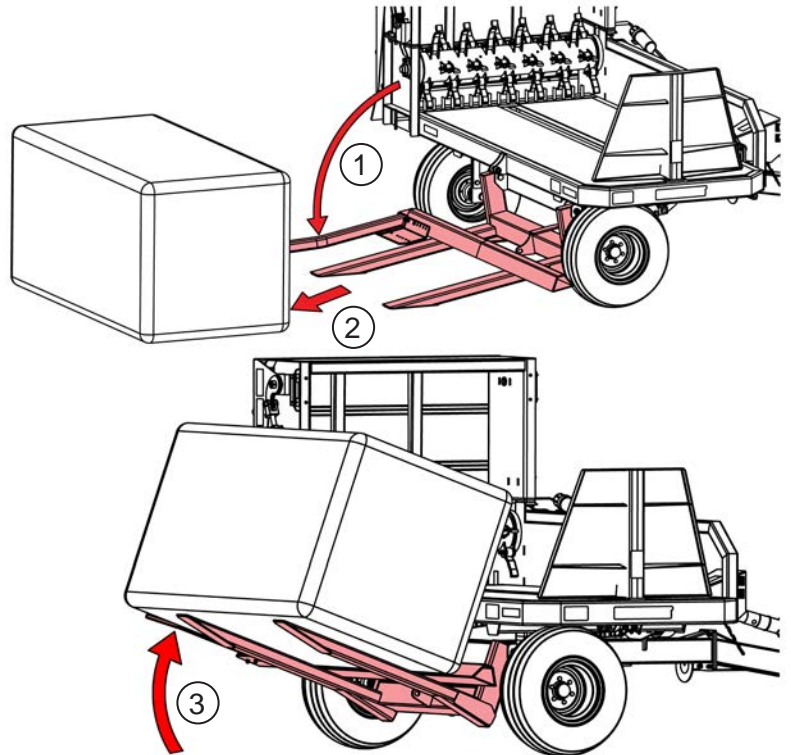

Spreading Bales

1. Set discharge flap to desired angle.
2. Slowly ramp up speed of PTO until flail drum is spinning freely. The flails should be fully extended. Operating power unit at maximum RPM. allows the processor to do a better job of chopping forage.
3. Push bale loaded on deck into flail drum using power unit hydraulic control designated to that function. After several bales you will find a suitable speed that allows both quick operation and a good feed out rate.
4. Reverse ram back to its fully opened position before loading the next bale using the bale fork.

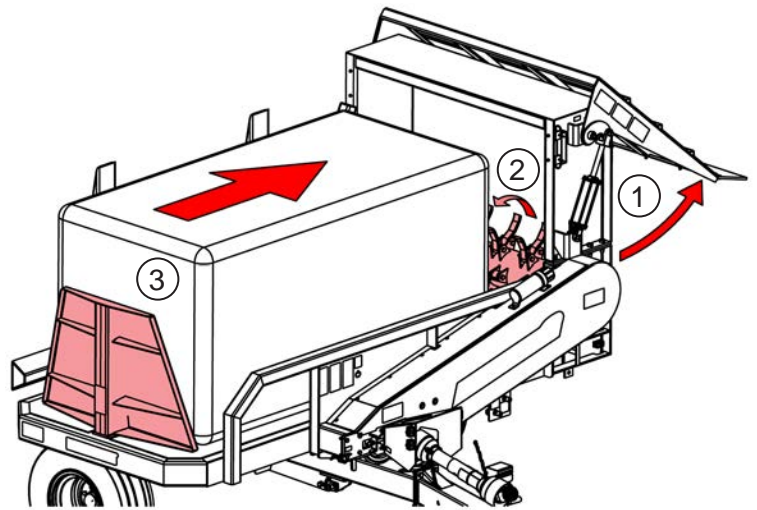

NOTE: Twine build-up should be kept to a minimum to reduce fire hazard and keep the machine in balance.

Transportation

Raise bale fork, close discharge flap before transporting. Disengage PTO, do not tow loads that weigh more than twice the weight of the tractor. Reduce the tractor's speed when ground is rough.

To assure adequate braking performance and control, tow only with an agricultural tractor. Safe towing speed depends on the weight of the tractor and the towed load. Speed should never exceed 32kmh (20mph). When transporting, be sure processor does not block view of vehicle lights or road.

Never operate controls from the ground. Operate the controls only from the operator's station. Never leave the equipment unattended with the engine running or with this product raised on the loader.

Be aware of the added weight and width of this product. Reduce travel speeds accordingly, especially when traveling over rough ground.

Drive slowly through gates and doors.

Section 4 - Processor Maintenance

Regular maintenance is the key to long equipment life and safe operation. It is very important that these maintenance functions be performed as described below.



Read and understand the safety instructions [Section 2 - Safety](#) before beginning any processor maintenance operation.

NOTE: The flail tube on this machine is a fully balanced assembly. If for any reason the flails must be removed, they must be returned to the same position they were taken from. If this is not done a balance problem will result in causing machine vibration. Number flails and inserts and their positions before you do any work.

Before First Use

Inspect the attachment for shipping damage. If damage does exist, do not operate until the damaged parts have been replaced or repaired.

Before Each Use

Check for loose or badly worn parts.

Conveyor chain should be adjusted to allow chain slack 1" (2.54 cm) to 1½" (3.8 cm).

Make sure that all hydraulic fittings are tightened and that there are no leaks in any fittings or hoses.

Inspect rotor and all rotating parts for twine or wire build-up.

Check for cylinder wear and broken flails and flail bracket wear. Replace with new "Boss" flails to keep machine in balance.

Make sure that all safety decals are in place, are clean and are legible. [Refer to Safety Decals, pg. 2-3.](#)

After Every 10 Hours of Operation

Grease all roller bearings ([refer to diagram on page 8-1](#)).

Inspect and tighten Allen screws on bearing.

Repairs

Read and understand [Section 2 - Safety](#) before beginning any processor service.

When making repairs, use only genuine Tubeline parts or, for fasteners, hydraulic hoses or hydraulic fittings, use only properly rated parts.



WARNING

Hydraulic fluid under pressure can penetrate skin, resulting in serious injury or death.
Always relieve hydraulic pressure before disconnecting lines.

Shut off engine, set parking brake and relieve hydraulic pressure before connecting or disconnecting hydraulic lines. Refer to your power unit's manual for instruction on how to relieve hydraulic pressure in lines.

Before applying pressure to the system, be sure that all connections are tight and be sure there are no damaged hoses, lines or fittings.

Steam-clean the power unit before any installation is made to the hydraulic system.

Wheel nuts must be tightened at 150 km and periodically thereafter.

Flail bolts must be tightened before use and periodically thereafter.

PTO Driveline

PTO drive-line maintenance instructions must be read before attaching and operating. The maintenance instructions are attached to the chain supplied on the drive-line.

Failure to do so may result in damage to the drive-line and machine may void warranty.

When lubricating drive-line telescoping shafts, it is imperative that yokes remain phased. In order to maintain phasing, the flat profile of the inner tube must be engaged with the flat profile of the outer tube. Failure to do so will result in damage across and bearings and premature shearing of the shear bolt.

Shear bolt replacement must be done only with shear bolts of the same grade and diameter supplied on the drive-line.

Storage

Always park the processor on level ground, preferably in an enclosed area. Block tires to avoid rolling.

Grease Points

ITEM	QTY	PART NUMBER	DESCRIPTION
1	1	37849	Grease Line Mount
2	1	GR 1/4 X 28	Grease Fitting 1/4-28 Straight Standard Zerk
3	1	HNJ3/8-16	Hex Nut - 3/8-16 Zinc Plated Hex Jam Nut

ITEM	QTY	AREA	TIMELINE	TYPE
A	4	Bed Chain Flange Bearings	Monthly	No.2 Extreme Pressure Grease
B	2	Flail Drum Flange Bearings	Weekly	
C	2	PTO Drive Shaft Flange Bearing	Weekly	
D	2	Deflector Shield Hinge Pins	Annually	
E	1	Bed Drive Roller Chain	Monthly	No.2 White Grease (Aerosol)
F	1	Bed Chain	Annually	

Grease Point Locations

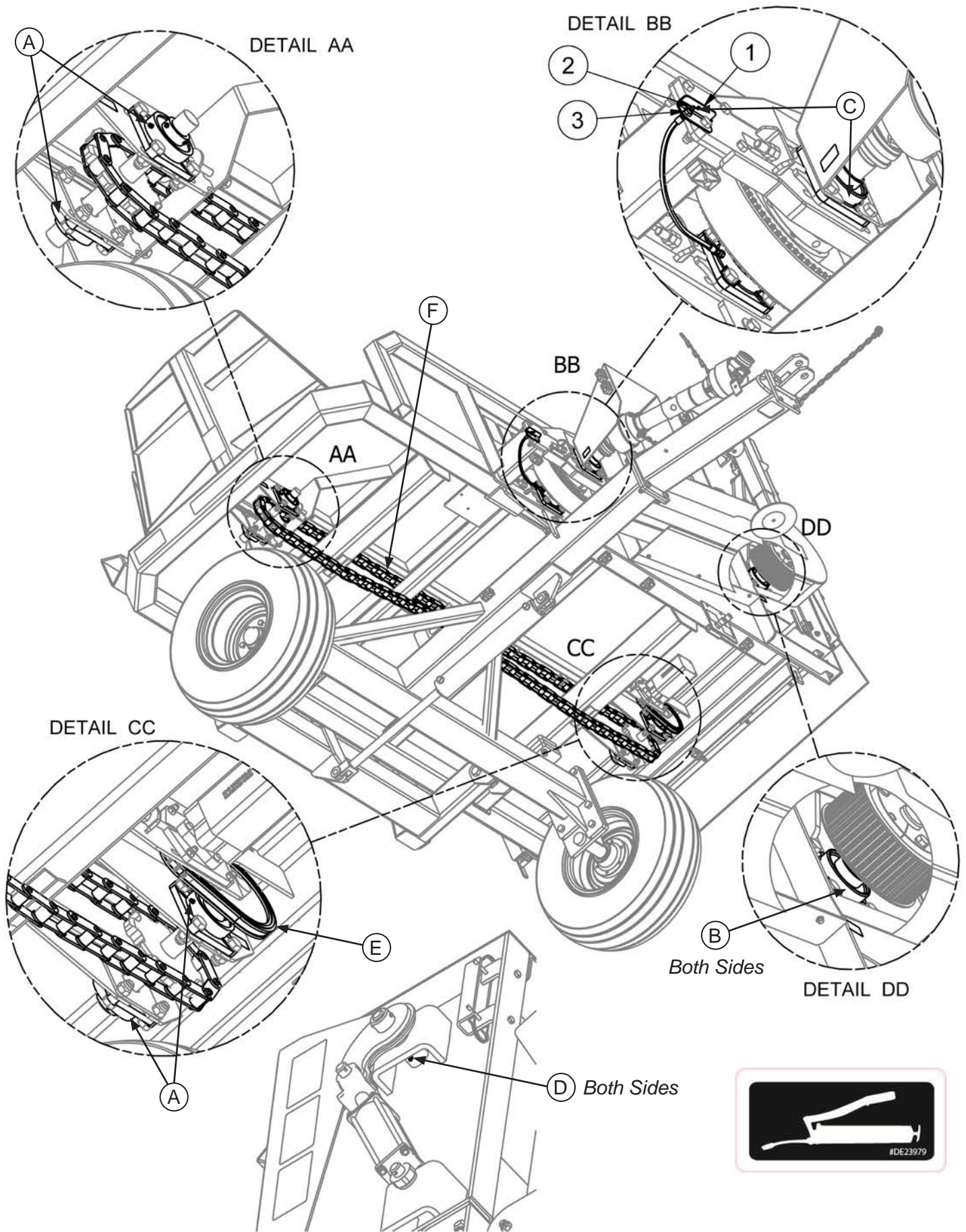

Section 5 - Part Breakdowns & Lists

Hitch Frame

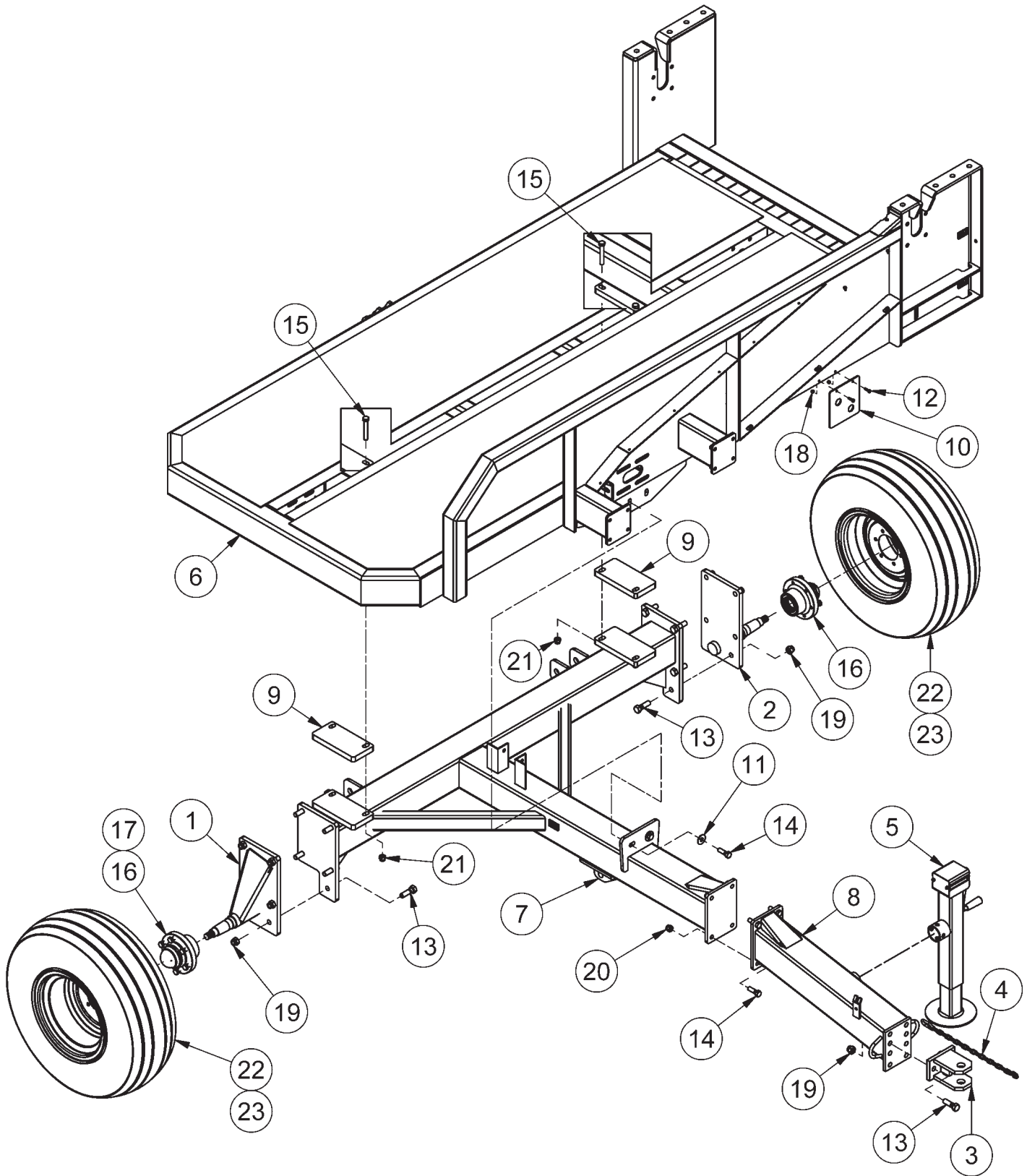

Hitch Frame

ITEM	QTY	PART NUMBER	DESCRIPTION	NOTE
1	1	208120	Spindle Weldment RH	
2	1	208121	Spindle Weldment LH	
3	1	208148	Bolt-on Tongue	
4	1	25261	Safety Chain 10000 # 59"	
5	1	25719	Heavy Duty Jack	
6	1	39000	Boss II HD Main Base	
7	1	39003	Main Hitch	
8	1	39004	Bolt-on Hitch	
9	2	39065	Main Hitch Mount	
10	1	43969	HRP 0.188 in	
11	4	FW 5/8	Flatwasher - 5/8" Zinc Plated USS	
12	2	HB1/4-20X1Z5	Hex Bolt 1/4-20x1 Grade 5 Zinc Plated Hex Cap Screw	
13	12	HB3/4-10X2.5Z5	Hex Bolt 3/4-10x2 1/2 Gr.5 Zinc Plated Hex Cap Screw	
14	6	HB5/8-11X2Z5	Hex Bolt 5/8-11x2 Gr.5 Zinc Plated Hex Cap Screw	
15	4	HB5/8-18X4YZ8	Hex Bolt 5/8-18x4 Gr.8 Zinc Hex Cap Screw	
16	2	HUB 6000#	Hub Assembly HUB6000	Inc. Item 16
17	2	HUB 6000-CCS	Seals and Bearing Kit HUB6000	
18	2	LN1/4-20NCZ5	LN 1/4-20 Zinc Plated Nylon Insert Lock Nut	
19	12	LN3/4-10NCZ5	LN 3/4-10 Zinc Plated Nylon Insert Lock Nut	
20	6	LN5/8-11NCZ5	LN 5/8-11 Zinc Plated Nylon Insert Lock Nut	
21	4	LN5/8-18NFZ8	5/8-18 Gr.8 Zinc Nylon Lock Nut	
22	2	WHE 12X15X10	12 x 15 10 Ply on 15x10x6 Bolt Rim	Standard
23	2	WHE 31-15.5-15	Boss II Lug Tire Assembly on 15x10x6 Bolt Rim	Optional

Flail Drum - Current

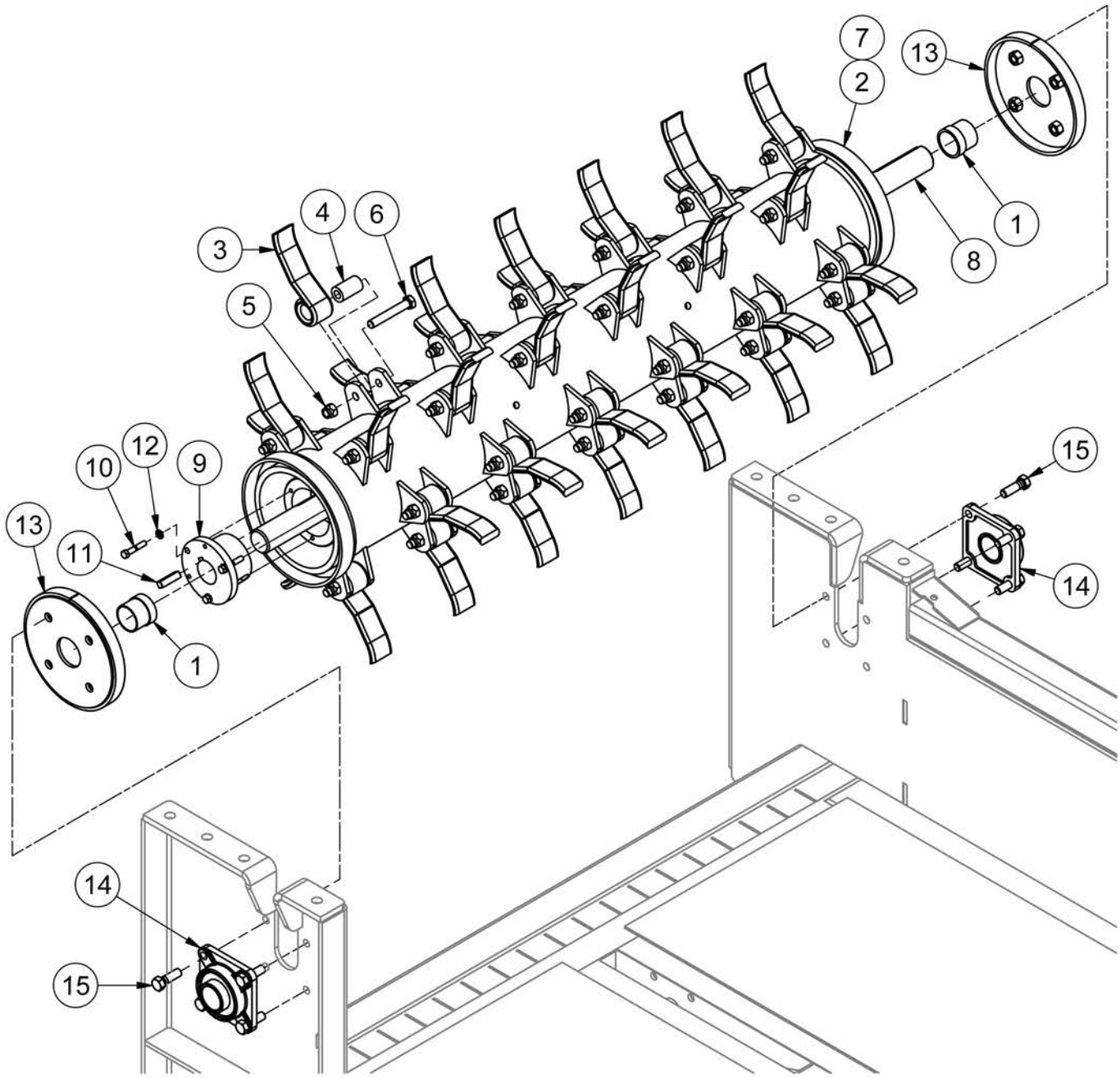

Flail Drum - Old Style(s)

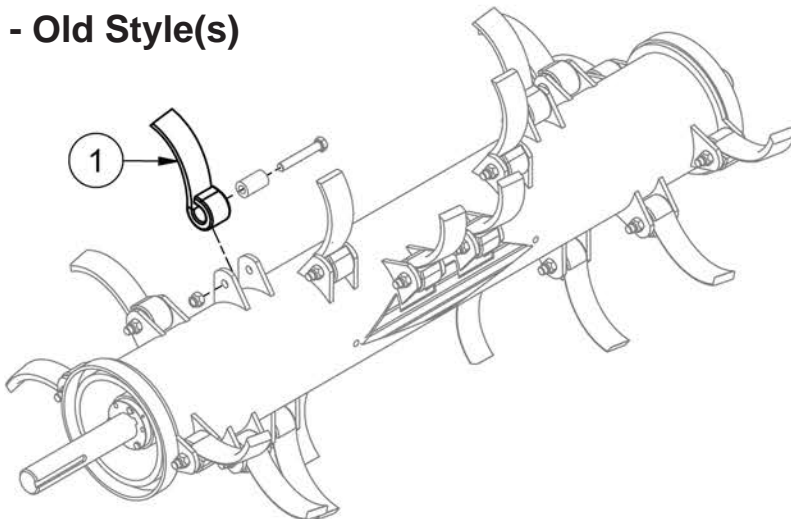

Flail Drum - Current

ITEM	QTY	PART NUMBER	DESCRIPTION	NOTE
1	2	39102	Beater Shaft Spacer	
2	1	50079	Boss II HD Drum (w/flails)	Inc. Items 3-7
3	38	BS200060A-1	Hammers, Heavy for Boss Shredder - 7/16 Material	
4	38	BS SAW200059	Flail Bushing	
5	38	LN5/8-18NFZ8	5/8-18 Gr.8 Zinc Nylon Lock Nut	
6	38	HB5/8-18X4YZ8	Hex Bolt 5/8-18x4 Grade 8 Zinc Hex Cap Screw	
7	1	50080	Boss II Flail Beater Weldment	Inc. Items 8-12
8	1	37789	Main Beater Shaft	
9	2	46982	R1x2" Split Taper Bushing	
10	6	HB3/8-16X2Z5	Hex Bolt 3/8-16x2 Grade 5 Zinc Plated Hex Cap Screw	
11	1	KS51356	Keystock .5 x 2.0	
12	6	LW 3/8	LW - 3/8" Zinc Plated Medium Split	
13	2	208141	Bearing Protector	
14	2	BEA UCF210-32R3	2" Bearing 4-Bolt Ductile Iron Flange with Triple Seal	BS199399A
15	8	HB5/8-11X2Z5	Hex Bolt 5/8-11x2 Grade 5 Zinc Plated Hex Cap Screw	

Flail Drum - Old Style(s)

ITEM	QTY	PART NUMBER	DESCRIPTION
1	20	BS200060A-2	Hammers, Heavy for Boss Shredder - 5/8 X 2.0 Material Tapered

Belt Drive

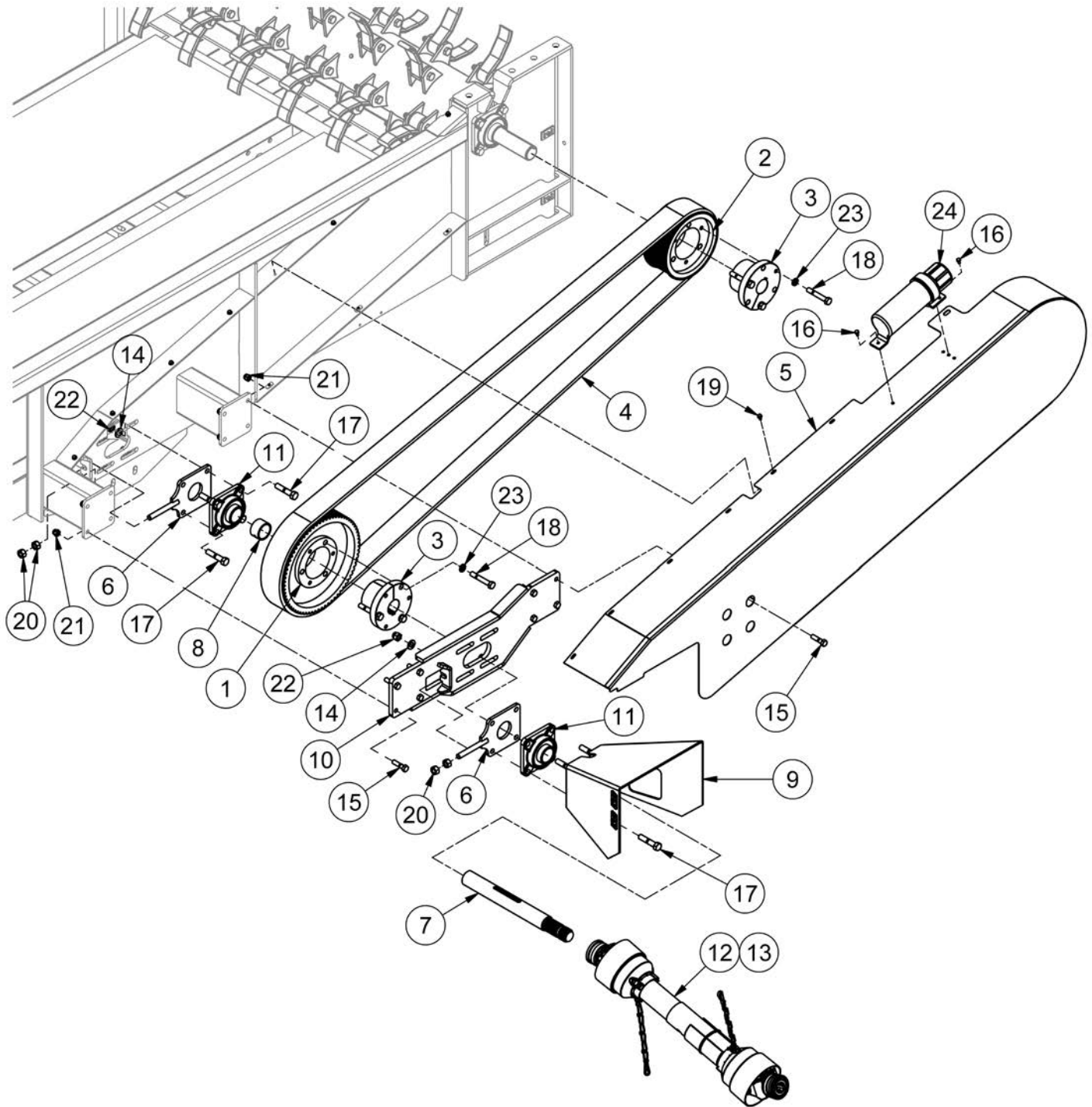

Belt Drive

ITEM	QTY	PART NUMBER	DESCRIPTION	NOTE
1	1	28005	Boss IV Pulley P80	
2	1	28006	Boss IV Pulley P64	
3	2	28007	Boss IV Bushing	
4	1	28008	Boss IV Belt	
5	1	39005	Belt Shield	
6	2	39007	Pulley Bearing Adjuster	
7	1	39086	PTO Drive Shaft	
8	1	39104	Back PTO Shaft Spacer	
9	1	40985	PTO Shield (Weldment)	
10	1	41446	Pulley Bearing Mount (Weldment)	
11	4	BEA UCF210-32R3	2.00 Bearing 4 Bolt Ductile Flange w/ Locking Collar	
12	1	BS208140	Boss II PTO 1000RPM	Standard
13	1	BS208540	Boss II PTO 540 RPM	Option
14	8	FW 5/8	Flatwasher - 5/8" Zinc Plated USS	
15	8	HB1/2-13X2Z5	Hex Bolt 1/2-13x2 Gr.5 Zinc Plated Hex Cap Screw	
16	2	HB1/4-20X0.5Z5	Hex Bolt 1/4-20x1/2 Gr.5 Zinc Plated Hex Cap Screw	
17	8	HB5/8-11X3Z5	Hex Bolt 5/8-11x3 Gr.5 Zinc Plated Hex Cap Screw	
18	6	HB9/16-13X3.5Z5	Hex Bolt 9/16-13x3 1/2 Gr.5 Zinc Plated Hex Cap Screw	
19	10	HBC1/4X0.5	Hex Bolt Cerrated 1/4-20 x 1/2 Zinc Flange Bolt	
20	4	HN5/8-11CZ5	Hex Nut 5/8"-11 Grade 5 Zinc Plated Finished	
21	8	LN1/2-13NCZ5	LN 1/2-13 Zinc Plated Nylon Insert Lock Nut	
22	8	LN5/8-11NCZ5	LN 5/8-11 Zinc Plated Nylon Insert Lock Nut	
23	6	LW 9/16	LW - 9/16" Zinc Plated Medium Split	
24	1	TL5X2-201-111	Operator's Manual Holder	

Fork

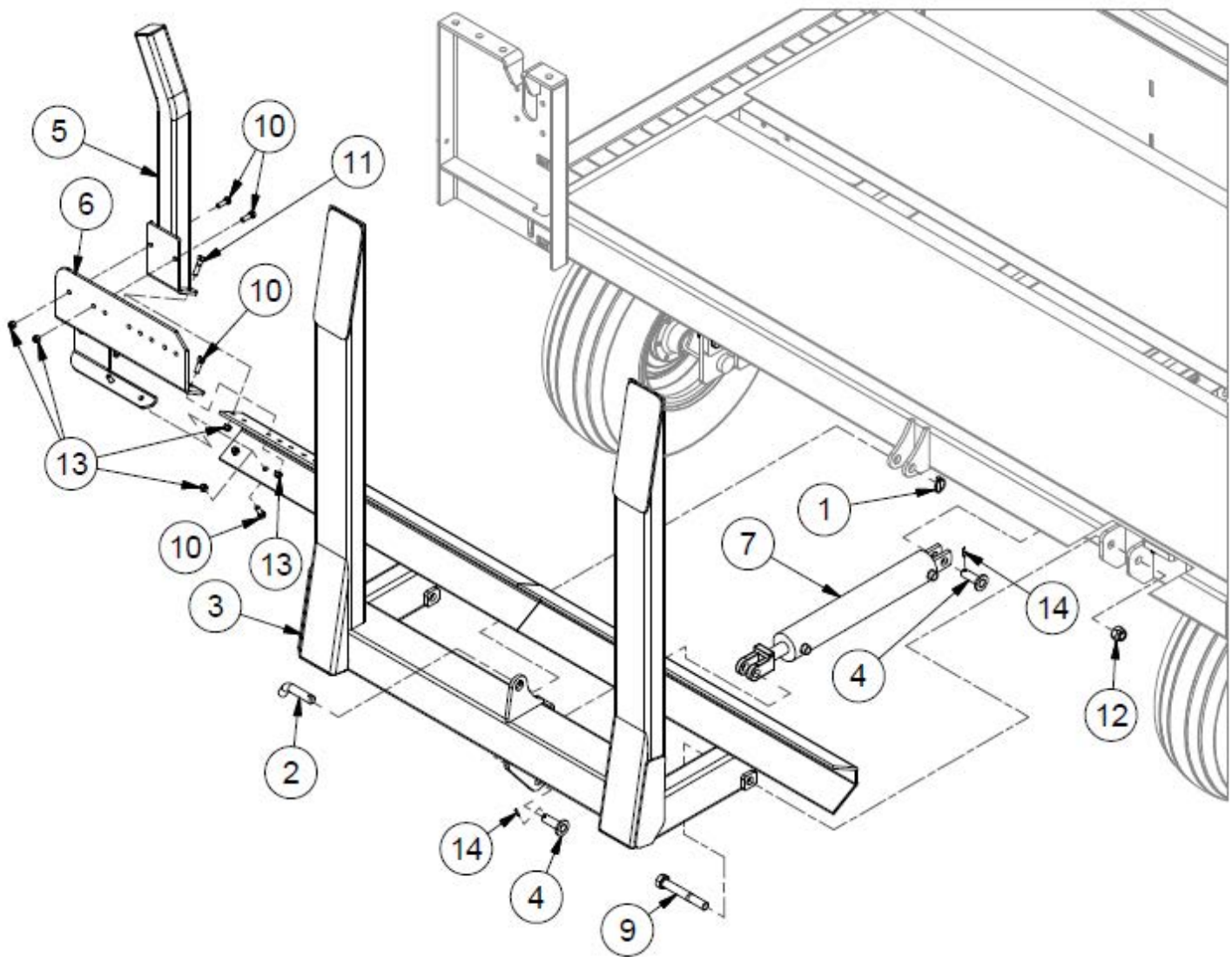

ITEM	QTY	PART NUMBER	DESCRIPTION
1	1	28940	Lynch Pin - 3/8 x 1-3/4"
2	1	36669	Transport Lock Pin
3	1	37541	Fork Lift
4	6	39010	Cylinder Pin (Weldment)
5	1	39011	Bale Guide Finger (Weldment)
6	1	39099	Dribbler
7	1	BS199899A	Cylinder, Boss II Fork (Lift) - 3-1/2" X 20-1/2" Hydraulic Cylinder
8	2	BS208141	Bearing Protector for Rotor
9	2	HB 1-8X7.0 Z5	Hex Bolt 1"-8 x 7" Grade 5 Zinc Plated Hex Cap Screw NC
10	7	HB 1/2-13X1.1/2 Z5	Hex Bolt 1/2-13 x 1 1/2" Grade 5 Zinc Plated Hex Cap Screw NC
11	9	HB 1/2-13X2.0 Z5	Hex Bolt 1/2-13 x 2" Grade 5 Zinc Plated Hex Cap Screw NC
12	2	LN 1.0 N	Locknuts - 1-8 Zinc Plated Nylon Insert
13	5	LN 1/2 N	Locknuts - 1/2-13 Zinc Plated Nylon Insert Lock Nut
14	6	RP 3/16X1.1/4	Pin - Slotted Spring Pin 3/16 x 1 1/4

Ram

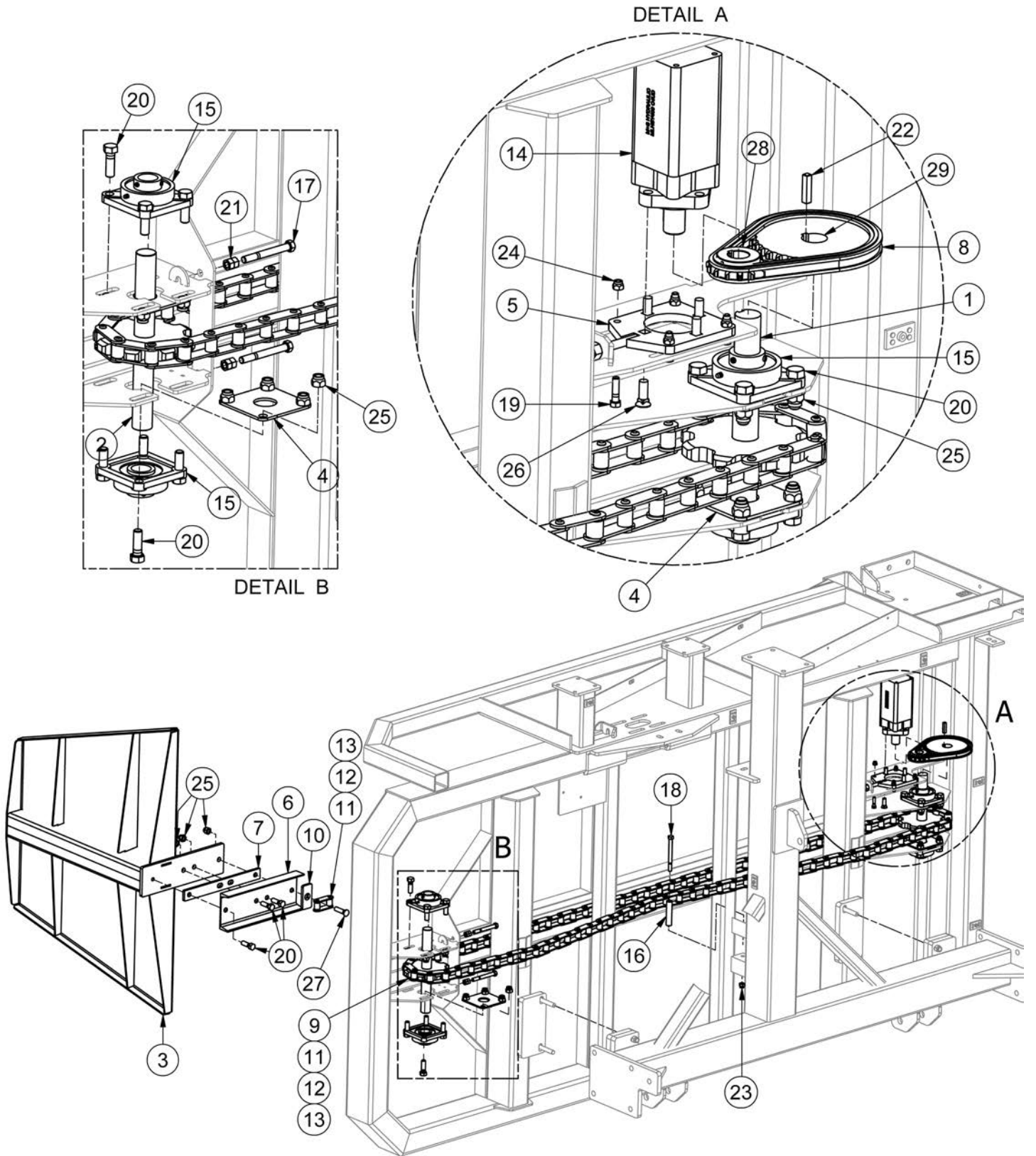

Ram

ITEM	QTY	PART NUMBER	DESCRIPTION	NOTE
1	1	27263	Ram Sprocket	
2	1	27264	Ram Idler	
3	1	37546	Bale Pusher (Weldment)	
4	4	37619	Spacer	
5	1	39008	Ram Motor Plate (Weldment)	
6	1	39085	Bale Pusher Mount	
7	1	39811	Bale Pusher Guide	
8	1	39997	Chain #60 X 39 Links c/w Connector Link	
9	1	41876	Boss II Ram Chain	Inc Items 10-13
10	1	BS PCT200146	Chain Pusher Mount	
11	88	CHAIN 081X	Plain Chain	
12	1	CHAIN 081X CON	Plain Chain - Connector Link	
13	2	CHAIN 081X LINK	Plain Chain - Half Link	
14	1	44930	Hydraulic Motor	
15	4	BEA UCF208-24-1.5	1 1/2" 4 Bolt Flange Bearing	
16	1	BS SAW200040	Tee Handle/Chain Roller	
17	2	HB 1/2-13X4.1/2 TZ5	Tap Bolt - 1/2"-13 X 4.1/2" Gr 5 Zinc Plated Tap Bolt N.C.	
18	1	HB1/2-13X5.5Z5	Hex Bolt 1/2-13x5 1/2 Gr 5 Zinc Plated Hex Cap Screw	
19	4	HB3/8-16X1.5Z5	Hex Bolt 3/8-16x1 1/2 Gr 5 Zinc Plated Hex Cap Screw	
20	19	HB5/8-11X2Z5	Hex Bolt 5/8-11x2 Gr 5 Zinc Plated Hex Cap Screw	
21	4	HN1/2-13CZ5	Hex Nut 1/2"-13 Gr 5 Zinc Plated Finished	
22	1	KS41537	Keystock .375 x .375 x 1.75	
23	1	LN1/2-13NCZ5	LN 1/2-13 Zinc Plated Nylon Insert Lock Nut	
24	4	LN3/8-16NCZ5	LN 3/8-16 Zinc Plated Nylon Insert Lock Nut	
25	19	LN5/8-11NCZ5	LN 5/8-11 Zinc Plated Nylon Insert Lock Nut	
26	4	PB 1/2-13X1.5	Plow Bolts - 1/2-13 x 1 1/2 Flat Head Gr.5	
27	1	PB 5/8-11X2.5	Plow Bolts - 5/8-11 x 2 1/2 Flat Head Gr.5	
28	1	SPR60B14-1.25	60B14 Sprocket w/1.25 Bore 5/16 Kw. 2 5/16 SS	
29	1	SPR60B30F-IH	60B30F 1-1/2" KW 2SS	

Deflector Shield

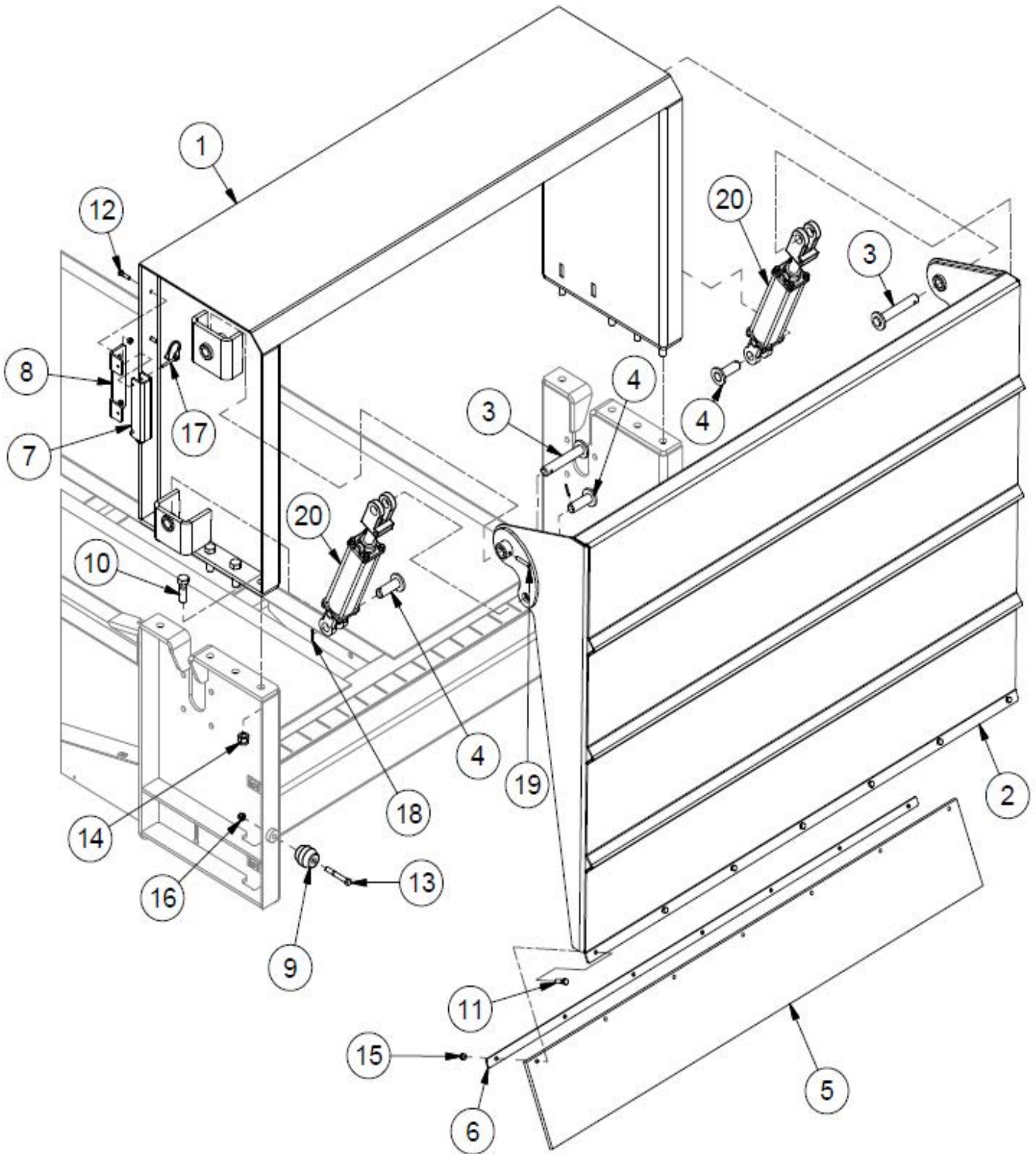

Deflector Shield

ITEM	QTY	PART NUMBER	DESCRIPTION
1	1	39001	Top Frame (Weldment)
2	1	39006	Deflector Shield (Weldment)
3	2	39009	Cylinder Pin (Weldment)
4	4	39010	Cylinder Pin (Weldment)
5	1	39088	Rubber Deflector .5 x 10 x 67 11/16
6	1	39089	Rubber Deflector Hold Down
7	2	39876	Cyl Channel Lock
8	2	39878	Cyl Lock Mount
9	2	40950	Timbren Bushing
10	8	HB3/4-10X2.5Z5	Hex Bolt 3/4-10x2 1/2 Grade 5 Zinc Plated Hex Cap Screw
11	7	HB3/8-16X1.5Z5	Hex Bolt 3/8-16x1 1/2 Grade 5 Zinc Plated Hex Cap Screw
12	4	HB5/16-18X1.25Z5	Hex Bolt 5/16-18x1 1/4 Grade 5 Zinc Plated Hex Cap Screw
13	2	HB7/16-14X3.25Z5	Hex Bolt 7/16-14x3 1/4 Grade 5 Zinc Plated Hex Cap Screw
14	8	LN3/4-10NCZ5	LN 3/4-10 Zinc Plated Nylon Insert Lock Nut
15	7	LN3/8-16NCZ5	LN 3/8-16 Zinc Plated Nylon Insert Lock Nut
16	2	LN7/16-14NCZ5	LN 7/16-14 Zinc Plated Nylon Insert Lock Nut
17	4	LP B1995	Pin - Lock Pin 1/4x1 3/4
18	4	RP 3/16 x 1 1/4	Pin - Roll Pin 3/16 x 1 1/4
19	2	RP 5/16 x 2	Pin - Roll Pin 5/16 x 2
20	2	TL500-100-082	Hydraulic Cylinder (HYS25SPE08-2176)

Hydraulic Layout - Original

See next page for available update kit.

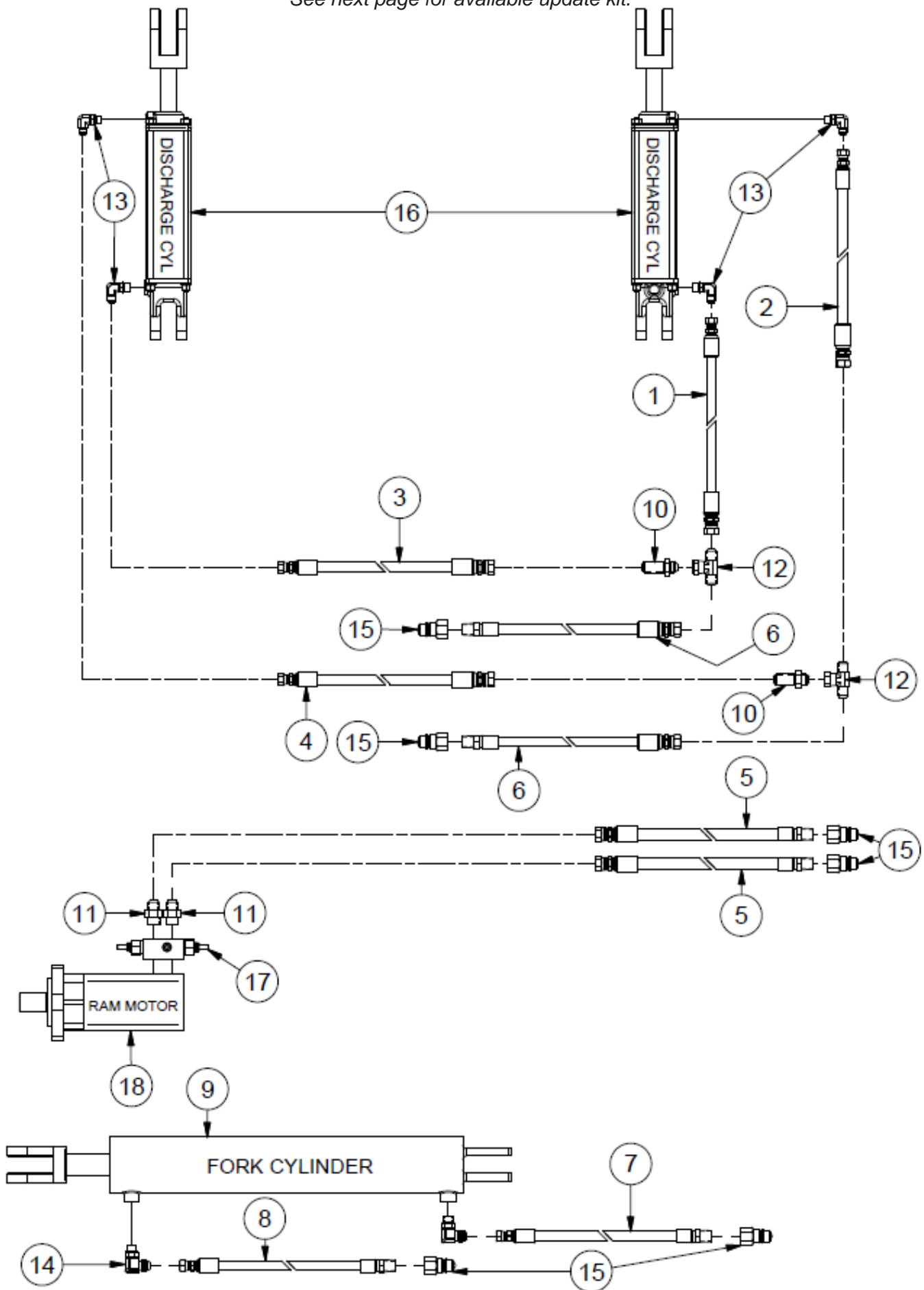

Hydraulic Layout - Original

See next page for available update kit.

ITEM	QTY	PARTNUMBER	DESCRIPTION
1	1	41542	HH43-6AT1(8FJX-6FJX) HCL 43"
2	1	41543	HH53-6AT1(8FJX-6FJX) HCL 53"
3	1	41544	HH91-6AT1(8FJX-6FJX) HCL 91"
4	1	41545	HH104-6AT1(8FJX-6FJX) HCL 104"
5	2	41551	HH167 - 8AT1(8MP,8FJXH) HCL 167"
6	2	44935	Hose - HH160 - 6AT1(8MP,8FJXH) HCL 160"
7	1	BS-09	Hose - HH120 - R17-063000PSI/109-08/MNPT-08/FJIC08/120C/MNPT-08
8	1	BS-10	Hose - HH140 - R17-063000PSI/109-06/MNPT-08/FJIC08/140C/MNPT-08
9	1	BS199899A	Cylinder, Boss II Fork (Lift) - 3-1/2" X 20-1/2" Hydraulic Cylinder
10	2	HF 2700LN-08-08	Hyd Fitting MJIC to MJIC
11	2	HF 6400-8-10	Hyd Fitting -Male JIC - Male ORB
12	2	HF 6600-8-8-8	Hyd. Fitting - Male JIC - Female JIC Tee
13	4	HF 6801-6-6	Hyd. Fitting 90 Deg.0-Ring to JIC
14	2	HF 6801-8-8	Hyd. Fitting- 1/2" JIC- 1/2" SAE 90 Deg Elbow
15	6	HF 8010-4	Quickcoupler 1/2" Male Tip
16	2	TL500-100-082	Hydraulic Cylinder (HYS25SPE08-2176)
17	1	VAL KPDS100/A/3	Relief Valve
18	1	VAL MLHSY400	Motor, Complete - MLHSY400C4UD

Hydraulic Layout - Original (Rev.1-0 Update)

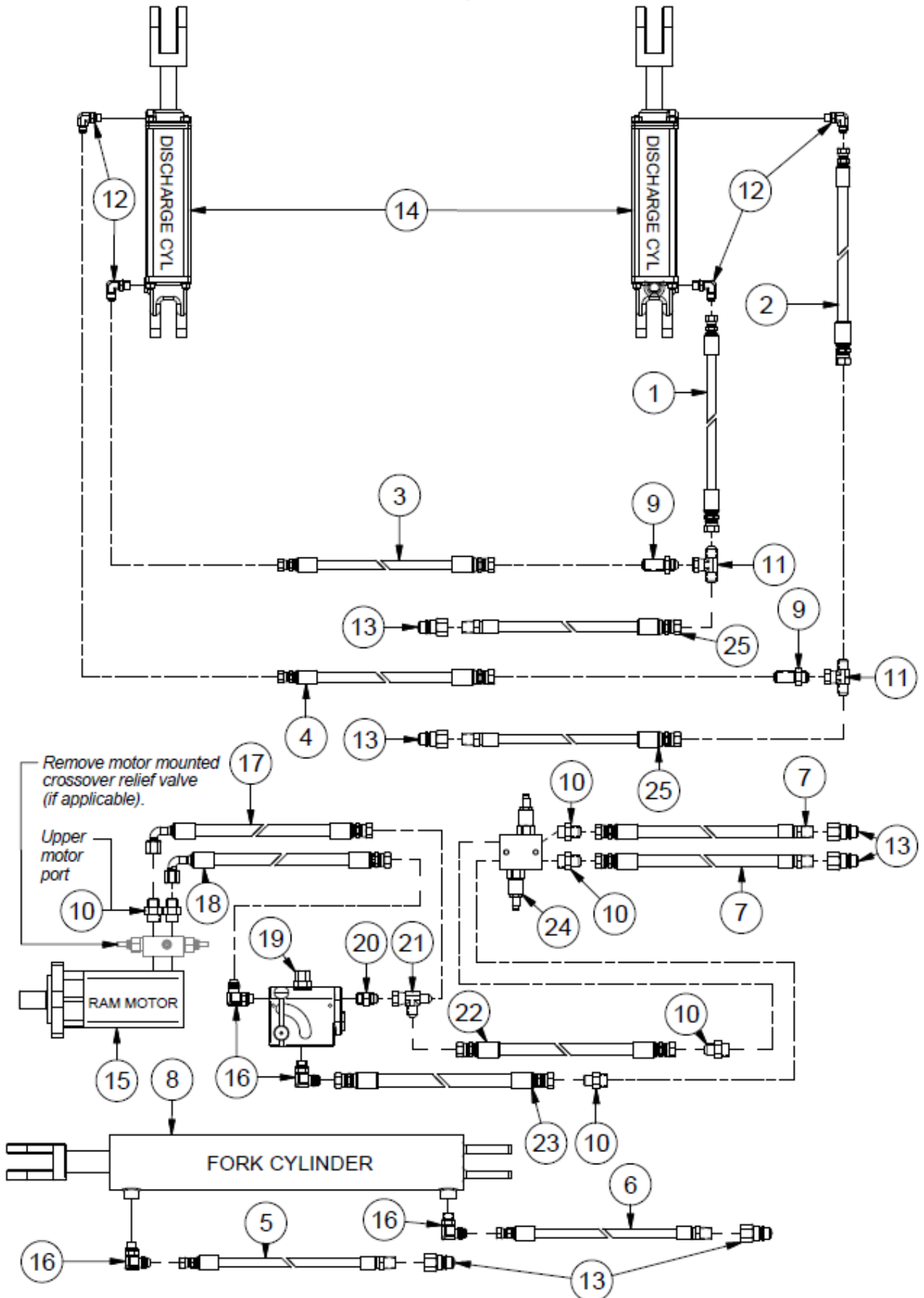

Hydraulic Layout - Original (Rev.1-0 Update)

ITEM	QTY	PARTNUMBER	DESCRIPTION
1	1	41542	HH43-6AT1(8FJX-6FJX) HCL 43"
2	1	41543	HH53-6AT1(8FJX-6FJX) HCL 53"
3	1	41544	HH91-6AT1(8FJX-6FJX) HCL 91"
4	1	41545	HH104-6AT1(8FJX-6FJX) HCL 104"
5	1	BS-10	Hose - HH140 - R17-063000PSI/109-06/MNPT-08/FJIC08/140C/MNPT-08
6	1	BS-09	Hose - HH120 - R17-063000PSI/109-08/MNPT-08/FJIC08/120C/MNPT-08
7	2	44981	Hose - HH76 - 8AT1(8MP,8FJXH) HCL 76"
8	1	BS199899A	Cylinder, Boss II Fork (Lift) - 3-1/2" X 20-1/2" Hydraulic Cylinder
9	2	HF 2700LN-08-08	Hyd Fitting MJIC to MJIC
10	6	HF 6400-8-10	Hyd Fitting -Male JIC - Male ORB
11	2	HF 6600-8-8-8	Hyd. Fitting - Male JIC - Female JIC Tee
12	4	HF 6801-6-6	Hyd. Fitting 90 Deg.0-Ring to JIC
13	6	HF 8010-4	Quickcoupler 1/2" Male Tip
14	2	TL500-100-082	Hydraulic Cylinder (HYS25SPE08-2176)
15	1	VAL MLHSY400	Motor, Complete - MLHSY400C4UD
16	4	HF 6801-8-8	Hyd. Fitting- 1/2" JIC- 1/2" SAE 90 Deg Elbow
17	1	44982	Hose - HH25 - 8AT1(8FJXH,8FJXH90S) 25"
18	1	44984	Hose - HH37 - 8AT1(8FJXH,8FJXH90S) 37"
19	1	42701	Flow Control with Relief
20	1	HF 6400-8-8	Hydraulic Fitting - O-Ring to JIC Adapter
21	1	HF 6602-8-8-8	Hydraulic T Fitting 18mm
22	1	30651	Hose - HH73- 8AT1(8FJXH-8FJXH) HCL 73"
23	1	44983	Hose - HH62 - 8AT1(8FJXH,8FJXH) 62"
24	1	43982	Cross line relief - 30 GPM 1600 psi.
25	2	44935	Hose - HH160 - 6AT1(8MP,8FJXH) HCL 160"

Hydraulic Layout - Current

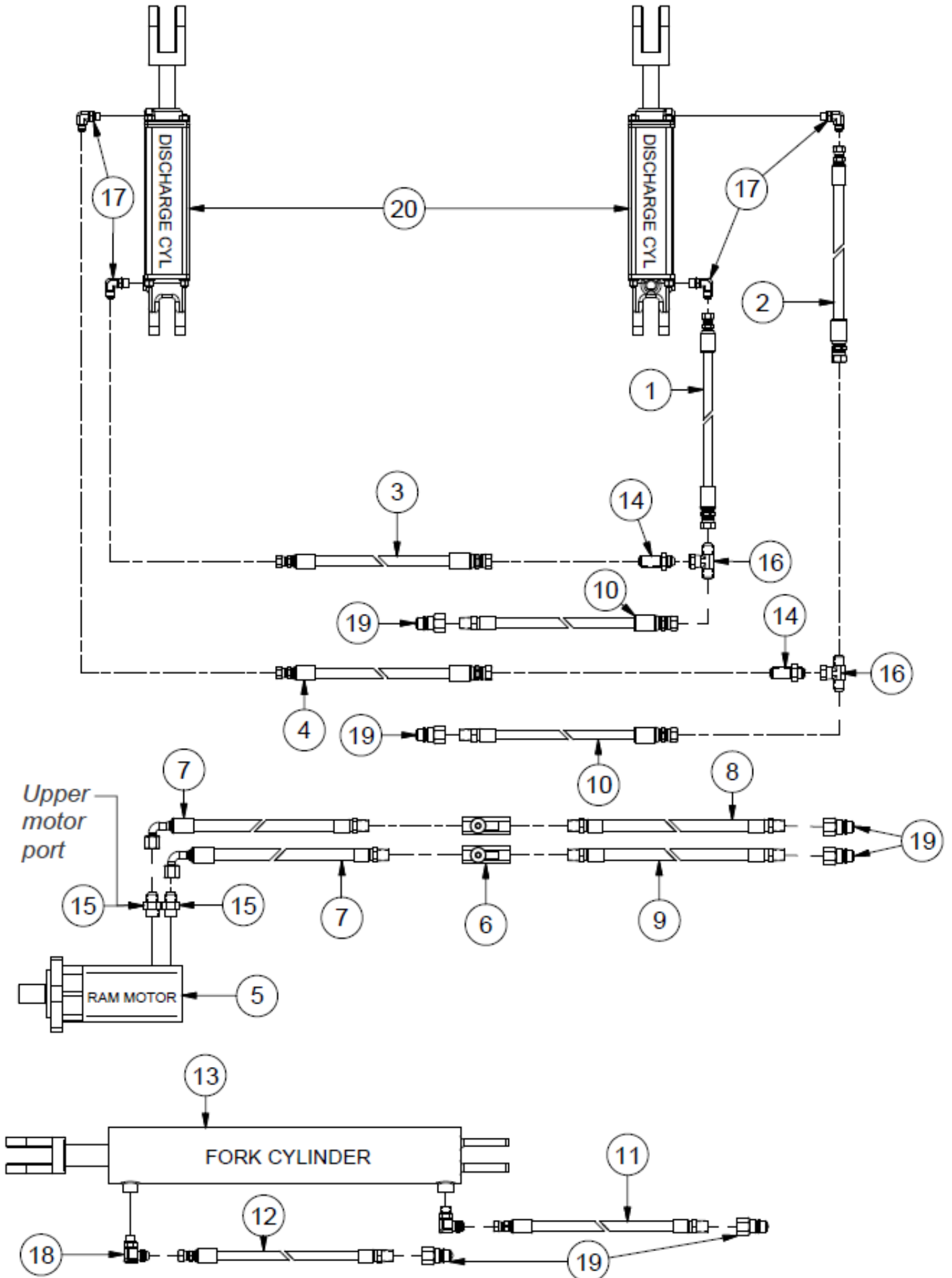

Hydraulic Layout - Current

ITEM	QTY	PARTNUMBER	DESCRIPTION
1	1	41542	HH43-6AT1(8FJX-6FJX) HCL 43"
2	1	41543	HH53-6AT1(8FJX-6FJX) HCL 53"
3	1	41544	HH91-6AT1(8FJX-6FJX) HCL 91"
4	1	41545	HH104-6AT1(8FJX-6FJX) HCL 104"
5	1	44930	Hydraulic Motor
6	2	44931	Flow Control 1/2NPT
7	2	44932	Hose - HH20 - 8AT1(8MP,8FJXH90) HCL 20"
8	1	44933	Hose - HH136 - 8AT1(8MP,8MP) HCL 136"
9	1	44934	Hose - HH139 - 8AT1(8MP,8MP) HCL 139"
10	2	44935	Hose - HH160 - 6AT1(8MP,8FJXH) HCL 160"
11	1	BS-09	Hose - HH120 - R17-063000PSI/109-06/MNPT-08/FJIC08/120C/MNPT-08
12	1	BS-10	Hose - HH140 - R17-063000PSI/109-08/MNPT-08/FJIC08/140C/MNPT-08
13	1	BS199899A	Cylinder, Boss II Fork (Lift) - 3-1/2" X 20-1/2" Hydraulic Cylinder
14	2	HF 2700LN-08-08	Hyd Fitting MJIC to MJIC
15	6	HF 6400-8-10	Hyd Fitting -Male JIC - Male ORB
16	2	HF 6600-8-8-8	Hyd. Fitting - Male JIC - Female JIC Tee
17	4	HF 6801-6-6	Hyd. Fitting 90 Deg.0-Ring to JIC
18	4	HF 6801-8-8	Hyd. Fitting- 1/2" JIC- 1/2" SAE 90 Deg Elbow
19	6	HF 8010-4	Quickcoupler 1/2" Male Tip
20	2	TL500-100-082	Hydraulic Cylinder (HYS25SPE08-2176)

BS208140 - 1000RPM PTO (Standard)

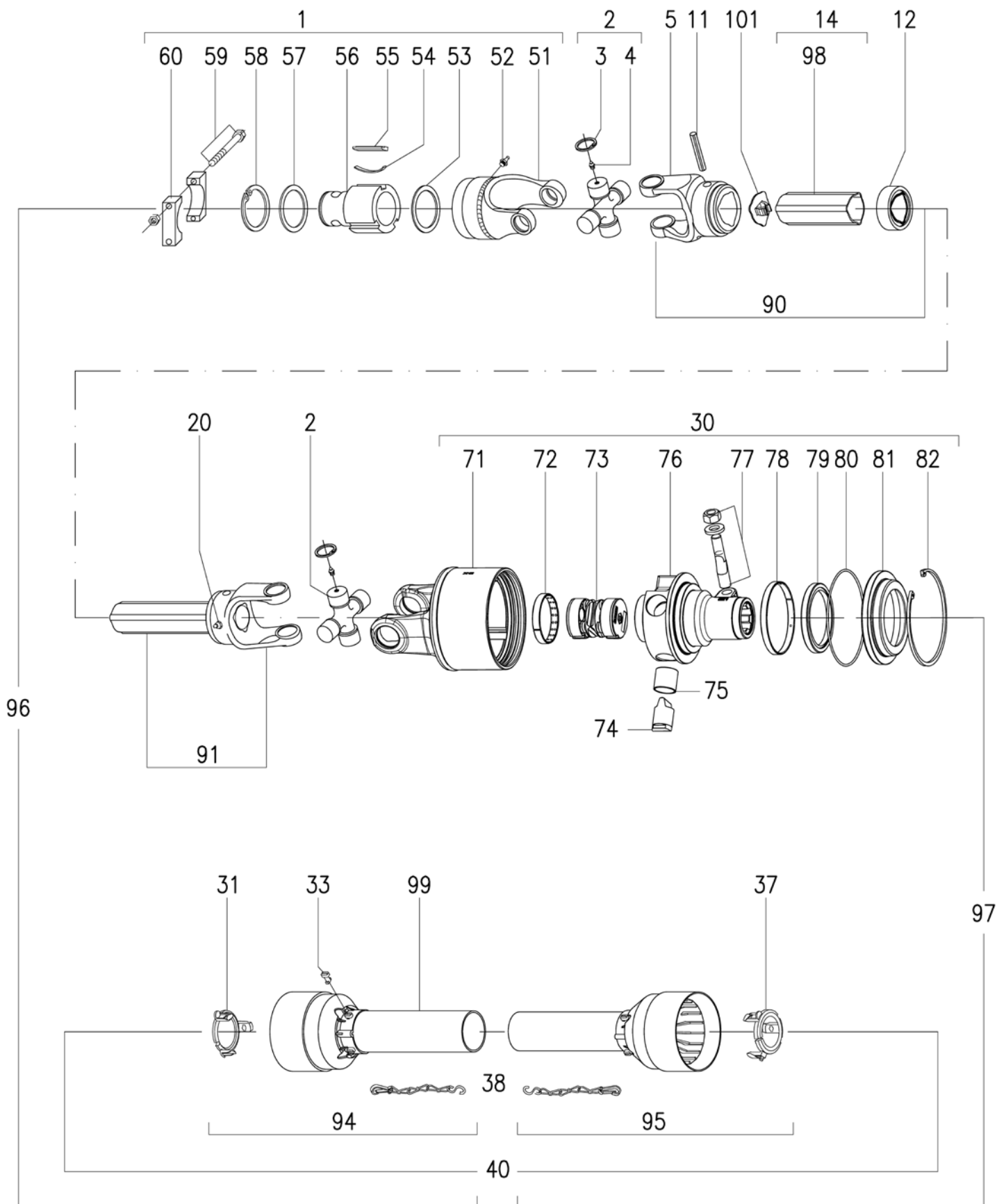

BS208140 - 1000RPM PTO (Standard)

ITEM	QTY	PART NUMBER	DESCRIPTION
1	1	PTO145.285.014.1	Complete Overrunning Clutch R14 (3800Nm)
2	2	PTO180.018.537	Cross Journal Set
5	1	PTO151.018.133.1	Outer Yoke
11	1	PTO190.000.243	Roll Pin for Outer Tube
12	1	PTO180.018.446	Wiper
14	1	PTO152.198.183.0720	Complete Outer Tube
20	1	PTO180.017.411	Grease Nipple for Lube
30	1	PTO144.386.063.1	Complete Automatic Torque Limiter LA4 (2700Nm)
31	1	PTO180.018.251	Guard Retaining Collar for Outer Tube
33	6	PTO180.014.240	Bolt
37	1	PTO180.018.252	Guard Retaining Collar for Inner Tube
38	2	PTO180.016.790	Safety Chains
40	1	PTO142.286.274.7821	Complete Guard with Instruction Manual
51	1	PTO141.028.210.1	Outer Casting With Yoke
52	1	PTO190.000.020	Grease Nipple M8x1
53	1	PTO190.000.199	Retaining Washer
54	3	PTO180.014.137	Leaf Spring
55	3	PTO151.014.136	Ratchet
56	1	PTO151.014.200	Hub R14 (1.75 Z6)
57	1	PTO180.014.135	Retaining Washer
58	1	PTO190.000.183	Inner Circlip
59	2	PTO165.000.622	Bolt M14x1.5x100 & Nut
60	2	PTO151.014.201	Bridge
71	1	PTO141.028.651.1	Yolk Support for Automatic Torque Limiter LA
72	1	PTO180.017.478	Inner Bushing
73	1	PTO141.027.616.2	Cartridge Limiter LA 2700Nm
74	4	PTO180.017.482	Ratchet Tooth LA
75	4	PTO190.000.845	Glycudor Bushing
76	1	PTO141.027.572.1	Hub LA4
77	1	PTO165.000.589	Tapered Pin Set 1.75"
78	1	PTO180.017.479	Outer Bushing
79	1	PTO19020.550.020	Oil Seal BASL
80	1	PTO18.7.6.01421	O-Ring
81	1	PTO19010.641.501	Cover for LA Limiter
82	1	PTO122.380.070.1	Snap Ring
90	1	PTO122.380.549.1	Female Tube with Yoke and Lube System
91	1	PTO142.283.274.7821	Male Tube with Yoke and Lube System
94	1	PTO142.287.170.7821	Half Female Guarding with Label
95	1	PTO123.380.463.11	Half Male Guarding
96	1	PTO123.480.751.11	Half Female Shaft with Guarding
97	1	PTO190.000.216	Half Male Shaft with Guarding
98	1	PTO190.000.215	DANGER Label for Outer Tube
99	1	PTO190.000.215	DANGER Label for Outer Guard Tube
100	1	PTO190.000.371	Instruction Manual
101	1	PTO180.018.341	Plastic Cap for Outer Tube

BS208540 - 540RPM PTO (Option)

Not available at time of publication. Please call the manufacturer.

BS208540 - 540RPM PTO (Option)

Not available at time of publication. Please call the manufacturer.

Wiring Harness - Diverter Valve Machines

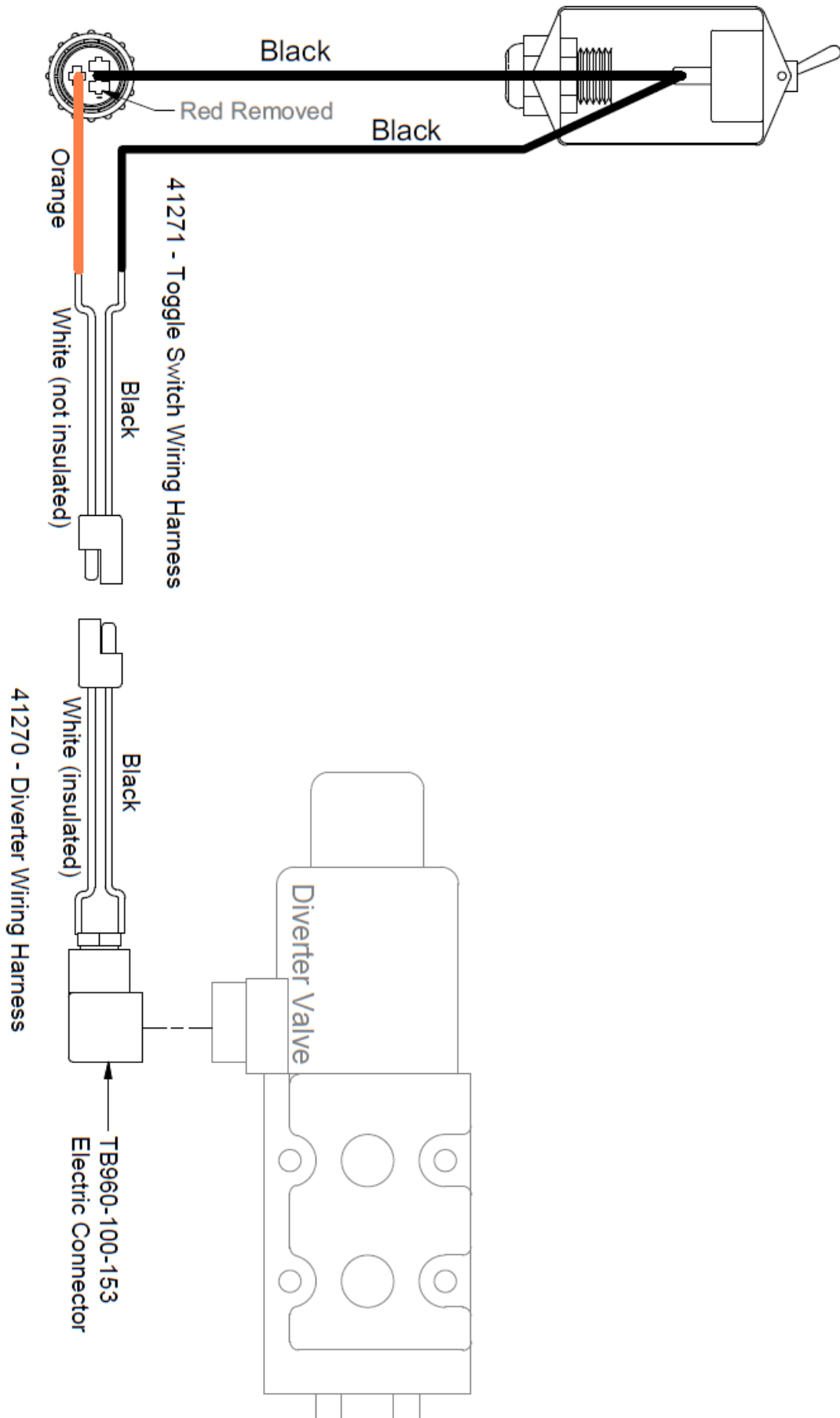





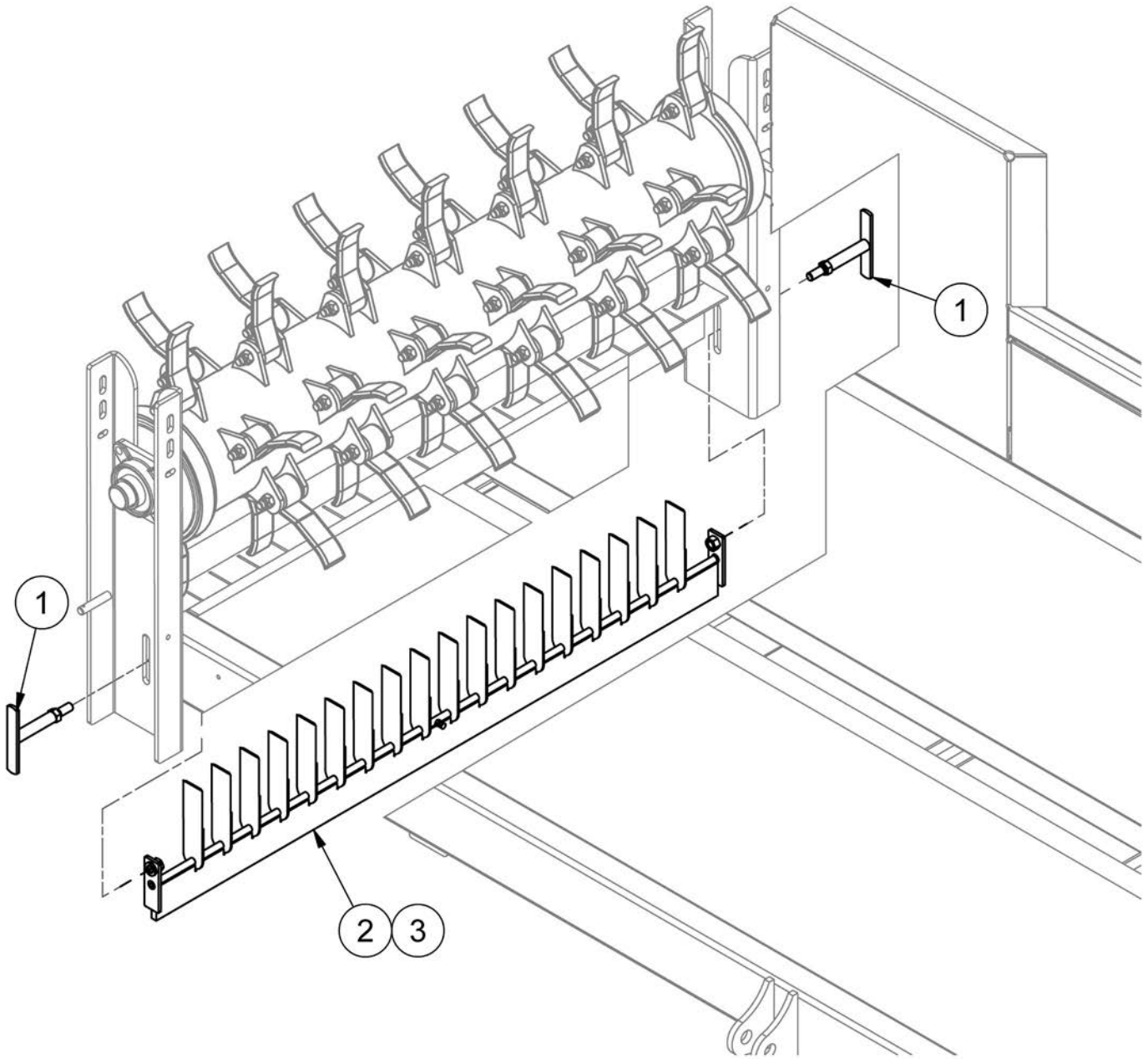





Section 5 - Options

BossCK - Adjustable Knife Kit



ITEM	QTY	PART NUMBER	DESCRIPTION	NOTE
1	2	BS200038	Tee Handle	
2	1	27234	Knife Assembly	Inc. Item 3
3	18	BS200058	Chopper Blade	

Imperial Torque Value Chart

SAE Grade and Head Markings	NO MARK 1 or 2 ^b 	5 	5.1 	5.2 	8 	8.2 
SAE Grade and Nut Markings	NO MARK 2 	5 			8 	

Size	Grade 1				Grade 2 ^b				Grade 5, 5.1, or 5.2				Grade 8 or 8.2			
	Lubricated ^a		Dry ^a		Lubricated ^a		Dry ^a		Lubricated ^a		Dry ^a		Lubricated ^a		Dry ^a	
	N-m	lb-ft	N-m	lb-ft	N-m	lb-ft	N-m	lb-ft	N-m	lb-ft	N-m	lb-ft	N-m	lb-ft	N-m	lb-ft
1/4	3.7	2.8	4.7	3.5	6	4.5	7.5	5.5	9.5	7	12	9	13.5	10	17	12.5
5/16	7.7	5.5	10	7	12	9	15	11	20	15	25	18	28	21	35	26
3/8	14	10	17	13	22	16	27	20	35	26	44	33	50	36	63	46
7/16	22	16	28	20	35	26	44	32	55	41	70	52	80	58	100	75
1/2	33	25	42	31	53	39	67	50	85	63	110	80	120	90	150	115
9/16	48	36	60	45	75	56	95	70	125	90	155	115	175	130	225	160
5/8	67	50	85	62	105	78	135	100	170	125	215	160	240	175	300	225
3/4	120	87	150	110	190	140	240	175	300	225	375	280	425	310	550	400
7/8	190	140	240	175	190	140	240	175	490	360	625	450	700	500	875	650
1	290	210	360	270	290	210	360	270	725	540	925	675	1050	750	1300	975
1-1/8	400	300	510	375	400	300	510	375	900	675	1150	850	1450	1075	1850	1350
1-1/4	570	425	725	530	570	425	725	530	1300	950	1650	1200	2050	1500	2600	1950
1-3/8	750	550	950	700	750	550	950	700	1700	1250	2150	1550	2700	2000	3400	2550
1-1/2	1000	725	1250	925	990	725	1250	930	2250	1650	2850	2100	3600	2650	4550	3350

DO NOT use these values if a different torque value or tightening procedure is given for a specific application. Torque values listed are for general use only. Check tightness of fasteners periodically.

Shear bolts are designed to fail under predetermined loads. Always replace shear bolts with identical grade.

Fasteners should be replaced with the same or higher grade. If higher grade fasteners are used, these should only be tightened to the strength of the original.

Make sure fasteners threads are clean and that you properly start thread engagement. This will prevent

them from failing when tightening.

Tighten plastic insert or crimped steel-type lock nuts to approximately 50 percent of the dry torque shown in the chart, applied to the nut, not to the bolt head. Tighten toothed or serrated-type lock nuts to the full torque value.

^a "Lubricated" means coated with a lubricant such as engine oil, or fasteners with phosphate and oil coatings. "Dry" means plain or zinc plated without any lubrication.

^b Grade 2 applies for hex cap screws (not hex bolts) up to 152 mm (6-in.) long. Grade 1 applies for hex cap screws over 152 mm (6-in.) long, and for all other types of bolts and screws of any length.

Metric Torque Value Chart

Property Class and Head Markings	4.8		8.8		9.8		10.9		12.9	
Property Class and Nut Markings	5		10		10		10		12	

Size	Class 4.8				Class 8.8 or 9.8				Class 10.9				Class 12.9			
	Lubricated ^a		Dry ^a		Lubricated ^a		Dry ^a		Lubricated ^a		Dry ^a		Lubricated ^a		Dry ^a	
	N-m	lb-ft	N-m	lb-ft	N-m	lb-ft	N-m	lb-ft	N-m	lb-ft	N-m	lb-ft	N-m	lb-ft	N-m	lb-ft
M6	4.8	3.5	6	4.5	9	6.5	11	8.5	13	9.5	17	12	15	11.5	19	14.5
M8	12	8.5	15	11	22	16	28	20	32	24	40	30	37	28	47	35
M10	23	17	29	21	43	32	55	40	63	47	80	60	75	55	95	70
M12	40	29	50	37	75	55	95	70	110	80	140	105	130	95	165	120
M14	63	47	80	60	120	88	150	110	175	130	225	165	205	150	260	190
M16	100	73	125	92	190	140	240	175	275	200	350	255	320	240	400	300
M18	135	100	175	125	260	195	330	250	375	275	475	350	440	325	560	410
M20	190	140	240	180	375	275	475	350	530	400	675	500	625	460	800	580
M22	260	190	330	250	510	375	650	475	725	540	925	675	850	625	1075	800
M24	330	250	425	310	650	475	825	600	925	675	1150	850	1075	800	1350	1000
M27	490	360	625	450	950	700	1200	875	1350	1000	1700	1250	1600	1150	2000	1500
M30	675	490	850	625	1300	950	1650	1200	1850	1350	2300	1700	2150	1600	2700	2000
M33	900	675	1150	850	1750	1300	2200	1650	2500	1850	3150	2350	2900	2150	3700	2750
M36	1150	850	1450	1075	2250	1650	2850	2100	3200	2350	4050	3000	3750	2750	4750	3500

DO NOT use these values if a different torque value or tightening procedure is given for a specific application. Torque values listed are for general use only. Check tightness of fasteners periodically.

Shear bolts are designed to fail under predetermined loads. Always replace shear bolts with identical property class.

Fasteners should be replaced with the same or higher property class. If higher property class fasteners are used, these should only be tightened to the strength of the original.

Make sure fasteners threads are clean and that you

properly start thread engagement. This will prevent them from failing when tightening.

Tighten plastic insert or crimped steel-type lock nuts to approximately 50 percent of the dry torque shown in the chart, applied to the nut, not to the bolt head. Tighten toothed or serrated-type lock nuts to the full torque value.

a "Lubricated" means coated with a lubricant such as engine oil, or fasteners with phosphate and oil coatings. "Dry" means plain or zinc plated without any lubrication.

Index

Adjustments3-1
After Every 10 Hours of Operation4-1
Bale Sizes1-1
Before Each Use4-1
Before First Use4-1
Belt Drive5-6
BossCK - Adjustable Knife Kit	5-25
BS208140 - 1000RPM PTO (Standard)	5-20
BS208540 - 540RPM PTO (Option)	5-22
Deflector Shield	5-12
Flail Drum - Current5-4
Flail Drum - Old Style(s).5-4
Fork5-8
General Safety2-1
Grease Point Locations4-3
Grease Points4-2
Hitch Frame5-2
Hydraulic Layout - Current	5-18
Hydraulic Layout - Original	5-14
Hydraulic Layout - Original (Rev.1-0 Update)	5-16
Hydraulic Safety2-2
Intended Use1-1
Loading Bales3-3
Maintenance Safety2-3
Manuals I
Operation Safety2-2
Orientation & Terminology1-1
Personal Protective Equipment2-1
Power Unit Specifications1-2
Processor Hookup3-2
PTO Driveline4-2
PTO Safety.2-2
Ram	5-10
Repairs4-1
Safety Decal Instructions2-3
Safety Decals - New Style2-4
Safety Decals - Old Style2-7
Safety Symbol.2-1
Safety Words2-1
Serial Number. I
Spreading Bales3-3
Starting Machine3-2
Storage4-2
Tire Safety2-3
Transportation.3-3
Using On Inclines.3-2
Warranty and Limitation of Liability I
Wheel Load Index Charts1-2
Wiring Harness - Diverter Valve Machines	5-24



Scan with smartphone to
download latest manual.



WARNING

The engine exhaust from this product contains chemicals known in the state of California to cause cancer, birth defects, or other reproductive harm.

TUBE•LINE™